

Quick Start Guide



Microwave Signal Generator

R&S® SMR20

1104.0002.20

R&S® SMR30

1104.0002.30

R&S® SMR27

1104.0002.27

R&S® SMR40

1104.0002.40

Printed in Germany



Dear Customer,

R&S® is a registered trademark of Rohde & Schwarz GmbH & Co. KG.
Trade names are trademarks of the owners.

Contents

1	Putting into Operation	1.1
	General Instructions	1.1
	Unpacking the Instrument	1.1
	Setting up the Instrument	1.1
	Supply Voltage.....	1.2
	How to Ensure EMC	1.2
	Power Fuses	1.2
	Switching On/Off the Instrument.....	1.2
	Initial Status	1.2
	RAM With Battery Back-Up.....	1.3
	Preset Setting	1.3
	Functional Test.....	1.3
	Mounting into a 19" Rack	1.3
	Explanation of Front and Rear Panel	1.4
	Elements of the Front Panel.....	1.4
	Elements of the Rear Panel	1.9
2	Short Tutorial	2.1
	Sample Setting for First Users.....	2.1
3	Manual Operation.....	3.1
	Design of the Display	3.1
	Basic Operating Steps	3.2
	Calling the menus.....	3.2
	Selection and Change of Parameters	3.3
	Quick Selection of Menu (QUICK SELECT)	3.4
	Use of [FREQ] and [LEVEL] Keys.....	3.5
	Use of [RF ON/OFF] and [MOD ON/OFF]	3.5
	Changing Unit of Level	3.5
	Correction of Input.....	3.6
	List Editor.....	3.7
	Select List.....	3.9
	Delete List	3.9
	Edit List.....	3.10
	SAVE/RECALL – Storing/Calling of Instrument Settings	3.15
	Menu Summary.....	3.16
4	Index	4.1



Before putting the product into operation for the first time, make sure to read the following

Safety Instructions



All plants and locations of the Rohde & Schwarz group of companies make every effort to keep the safety standard of our products up to date and to offer our customers the highest possible degree of safety. Our products and the auxiliary equipment required for them are designed and tested in accordance with the relevant safety standards. Compliance with these standards is continuously monitored by our quality assurance system. The product described here has been designed and tested in accordance with the EC Certificate of Conformity and has left the manufacturer's plant in a condition fully complying with safety standards. To maintain this condition and to ensure safe operation, observe all instructions and warnings provided in this manual. If you have any questions regarding these safety instructions, the Rohde & Schwarz group of companies will be happy to answer them.

Furthermore, it is your responsibility to use the product in an appropriate manner. This product is designed for use solely in industrial and laboratory environments or in the field and must not be used in any way that may cause personal injury or property damage. You are responsible if the product is used for an intention other than its designated purpose or in disregard of the manufacturer's instructions. The manufacturer shall assume no responsibility for such use of the product.

The product is used for its designated purpose if it is used in accordance with its product documentation and within its performance limits (see data sheet, documentation, the following safety instructions). Using the product requires technical skills and a basic knowledge of English. It is therefore essential that the product be used exclusively by skilled and specialized staff or thoroughly trained personnel with the required skills. If personal safety gear is required for using Rohde & Schwarz products, this will be indicated at the appropriate place in the product documentation.

Symbols and safety labels

Observe product documentation	Weight indication for units >18 kg	Danger of electric shock	Warning! Hot surface	PE terminal	Ground	Ground terminal	Attention! Electrostatic sensitive devices

Supply voltage ON/OFF	Standby indication	Direct current (DC)	Alternating current (AC)	Direct/alternating current (DC/AC)	Device fully protected by double/reinforced insulation

Safety Instructions

Observing the safety instructions will help prevent personal injury or damage of any kind caused by dangerous situations. Therefore, carefully read through and adhere to the following safety instructions before putting the product into operation. It is also absolutely essential to observe the additional safety instructions on personal safety that appear in relevant parts of the product documentation. In these safety instructions, the word "product" refers to all merchandise sold and distributed by the Rohde & Schwarz group of companies, including instruments, systems and all accessories.

Tags and their meaning

DANGER	This tag indicates a definite hazard carrying a high risk of death or serious injury if not avoided.
WARNING	This tag indicates a possible hazard carrying a medium risk of death or (serious) injury if not avoided.
CAUTION	This tag indicates a hazard carrying a low risk of minor or moderate injury if not avoided.
ATTENTION	This tag indicates the possibility of incorrect use that can cause damage to the product.
NOTE	This tag indicates a situation where the user should pay special attention to operating the product but which does not lead to damage.

These tags are in accordance with the standard definition for civil applications in the European Economic Area. Definitions that deviate from the standard definition may also exist in other economic areas or military applications. It is therefore essential to make sure that the tags described here are always used only in connection with the related product documentation and the related product. The use of tags in connection with unrelated products or documentation can result in misinterpretation and thus contribute to personal injury or material damage.

Basic safety instructions

1. The product may be operated only under the operating conditions and in the positions specified by the manufacturer. Its ventilation must not be obstructed during operation. Unless otherwise specified, the following requirements apply to Rohde & Schwarz products:
prescribed operating position is always with the housing floor facing down, IP protection 2X, pollution severity 2, overvoltage category 2, use only in enclosed spaces, max. operation altitude 2000 m above sea level, max. transport altitude 4500 m above sea level.
Unless specified otherwise in the data sheet, a tolerance of $\pm 10\%$ shall apply to the nominal voltage and of $\pm 5\%$ to the nominal frequency.
2. Applicable local or national safety regulations and rules for the prevention of accidents must be observed in all work performed. The product may be opened only by authorized, specially trained personnel. Prior to performing any work on the product or opening the product, the product must be disconnected from the supply network. Any adjustments, replacements of parts, maintenance or repair must be carried out only by technical personnel authorized by Rohde & Schwarz. Only original parts may be used for replacing parts relevant to safety (e.g. power switches, power transformers, fuses). A safety test must always be performed after parts relevant to safety have been replaced (visual inspection, PE conductor test, insulation resistance measurement, leakage current measurement, functional test).
3. As with all industrially manufactured goods, the use of substances that induce an allergic reaction (allergens, e.g. nickel) such as aluminum cannot be generally excluded. If you develop an allergic reaction (such as a skin rash, frequent sneezing, red eyes or respiratory difficulties), consult a physician immediately to determine the cause.

Safety Instructions

4. If products/components are mechanically and/or thermally processed in a manner that goes beyond their intended use, hazardous substances (heavy-metal dust such as lead, beryllium, nickel) may be released. For this reason, the product may only be disassembled, e.g. for disposal purposes, by specially trained personnel. Improper disassembly may be hazardous to your health. National waste disposal regulations must be observed.
5. If handling the product yields hazardous substances or fuels that must be disposed of in a special way, e.g. coolants or engine oils that must be replenished regularly, the safety instructions of the manufacturer of the hazardous substances or fuels and the applicable regional waste disposal regulations must be observed. Also observe the relevant safety instructions in the product documentation.
6. Depending on the function, certain products such as RF radio equipment can produce an elevated level of electromagnetic radiation. Considering that unborn life requires increased protection, pregnant women should be protected by appropriate measures. Persons with pacemakers may also be endangered by electromagnetic radiation. The employer/operator is required to assess workplaces where there is a special risk of exposure to radiation and, if necessary, take measures to avert the danger.
7. Operating the products requires special training and intense concentration. Make certain that persons who use the products are physically, mentally and emotionally fit enough to handle operating the products; otherwise injuries or material damage may occur. It is the responsibility of the employer to select suitable personnel for operating the products.
8. Prior to switching on the product, it must be ensured that the nominal voltage setting on the product matches the nominal voltage of the AC supply network. If a different voltage is to be set, the power fuse of the product may have to be changed accordingly.
9. In the case of products of safety class I with movable power cord and connector, operation is permitted only on sockets with earthing contact and protective earth connection.
10. Intentionally breaking the protective earth connection either in the feed line or in the product itself is not permitted. Doing so can result in the danger of an electric shock from the product. If extension cords or connector strips are implemented, they must be checked on a regular basis to ensure that they are safe to use.
11. If the product has no power switch for disconnection from the AC supply, the plug of the connecting cable is regarded as the disconnecting device. In such cases, it must be ensured that the power plug is easily reachable and accessible at all times (corresponding to the length of connecting cable, approx. 2 m). Functional or electronic switches are not suitable for providing disconnection from the AC supply. If products without power switches are integrated in racks or systems, a disconnecting device must be provided at the system level.
12. Never use the product if the power cable is damaged. Check the power cable on a regular basis to ensure that it is in proper operating condition. By taking appropriate safety measures and carefully laying the power cable, ensure that the cable cannot be damaged and that no one can be hurt by e.g. tripping over the cable or suffering an electric shock.
13. The product may be operated only from TN/TT supply networks fused with max. 16 A (higher fuse only after consulting with the Rohde & Schwarz group of companies).
14. Do not insert the plug into sockets that are dusty or dirty. Insert the plug firmly and all the way into the socket. Otherwise, this can result in sparks, fire and/or injuries.
15. Do not overload any sockets, extension cords or connector strips; doing so can cause fire or electric shocks.
16. For measurements in circuits with voltages $V_{\text{rms}} > 30 \text{ V}$, suitable measures (e.g. appropriate measuring equipment, fusing, current limiting, electrical separation, insulation) should be taken to avoid any hazards.
17. Ensure that the connections with information technology equipment comply with IEC 950/EN 60950.
18. Unless expressly permitted, never remove the cover or any part of the housing while the product is in operation. Doing so will expose circuits and components and can lead to injuries, fire or damage to the product.

Safety Instructions

19. If a product is to be permanently installed, the connection between the PE terminal on site and the product's PE conductor must be made first before any other connection is made. The product may be installed and connected only by a license electrician.
20. For permanently installed equipment without built-in fuses, circuit breakers or similar protective devices, the supply circuit must be fused in such a way that suitable protection is provided for users and products.
21. Do not insert any objects into the openings in the housing that are not designed for this purpose. Never pour any liquids onto or into the housing. This can cause short circuits inside the product and/or electric shocks, fire or injuries.
22. Use suitable overvoltage protection to ensure that no overvoltage (such as that caused by a thunderstorm) can reach the product. Otherwise the operating personnel will be endangered by electric shocks.
23. Rohde & Schwarz products are not protected against penetration of water, unless otherwise specified (see also safety instruction 1.). If this is not taken into account, there exists the danger of electric shock for the user or damage to the product, which can also lead to personal injury.
24. Never use the product under conditions in which condensation has formed or can form in or on the product, e.g. if the product was moved from a cold to a warm environment.
25. Do not close any slots or openings on the product, since they are necessary for ventilation and prevent the product from overheating. Do not place the product on soft surfaces such as sofas or rugs or inside a closed housing, unless this is well ventilated.
26. Do not place the product on heat-generating devices such as radiators or fan heaters. The temperature of the environment must not exceed the maximum temperature specified in the data sheet.
27. Batteries and storage batteries must not be exposed to high temperatures or fire. Keep batteries and storage batteries away from children. Do not short-circuit batteries and storage batteries.
If batteries or storage batteries are improperly replaced, this can cause an explosion (warning: lithium cells). Replace the battery or storage battery only with the matching Rohde & Schwarz type (see spare parts list). Batteries and storage batteries must be recycled and kept separate from residual waste. Batteries and storage batteries that contain lead, mercury or cadmium are hazardous waste. Observe the national regulations regarding waste disposal and recycling.
28. Please be aware that in the event of a fire, toxic substances (gases, liquids etc.) that may be hazardous to your health may escape from the product.
29. The product can be very heavy. Be careful when moving it to avoid back or other physical injuries.
30. Do not place the product on surfaces, vehicles, cabinets or tables that for reasons of weight or stability are unsuitable for this purpose. Always follow the manufacturer's installation instructions when installing the product and fastening it to objects or structures (e.g. walls and shelves).
31. Handles on the products are designed exclusively for personnel to hold or carry the product. It is therefore not permissible to use handles for fastening the product to or on means of transport such as cranes, fork lifts, wagons, etc. The user is responsible for securely fastening the products to or on the means of transport and for observing the safety regulations of the manufacturer of the means of transport. Noncompliance can result in personal injury or material damage.
32. If you use the product in a vehicle, it is the sole responsibility of the driver to drive the vehicle safely. Adequately secure the product in the vehicle to prevent injuries or other damage in the event of an accident. Never use the product in a moving vehicle if doing so could distract the driver of the vehicle. The driver is always responsible for the safety of the vehicle. The manufacturer assumes no responsibility for accidents or collisions.
33. If a laser product (e.g. a CD/DVD drive) is integrated in a Rohde & Schwarz product, do not use any other settings or functions than those described in the product documentation. Otherwise this may be hazardous to your health, since the laser beam can cause irreversible damage to your eyes. Never try to take such products apart, and never look into the laser beam.

Informaciones de seguridad



Por favor lea imprescindiblemente antes de la primera puesta en funcionamiento las siguientes



Informaciones de seguridad

El principio del grupo de empresas Rohde & Schwarz consiste en tener nuestros productos siempre al día con los standards de seguridad y de ofrecer a nuestros clientes el máximo grado de seguridad. Nuestros productos y todos los equipos adicionales son siempre fabricados y examinados según las normas de seguridad vigentes. Nuestra sección de gestión de la seguridad de calidad controla constantemente que sean cumplidas estas normas. El presente producto ha sido fabricado y examinado según el comprobante de conformidad adjunto según las normas de la CE y ha salido de nuestra planta en estado impecable según los standards técnicos de seguridad. Para poder preservar este estado y garantizar un funcionamiento libre de peligros, el usuario deberá atenerse a todas las informaciones, informaciones de seguridad y notas de alerta. El grupo de empresas Rohde & Schwarz está siempre a su disposición en caso de que tengan preguntas referentes a estas informaciones de seguridad.

Además queda en la responsabilidad del usuario utilizar el producto en la forma debida. Este producto solamente fue elaborado para ser utilizado en la industria y el laboratorio o para fines de campo y de ninguna manera deberá ser utilizado de modo que alguna persona/cosa pueda ser dañada. El uso del producto fuera de sus fines definidos o despreciando las informaciones de seguridad del fabricante queda en la responsabilidad del usuario. El fabricante no se hace en ninguna forma responsable de consecuencias a causa del mal uso del producto.

Se parte del uso correcto del producto para los fines definidos si el producto es utilizado dentro de las instrucciones de la correspondiente documentación de producto y dentro del margen de rendimiento definido (ver hoja de datos, documentación, informaciones de seguridad que siguen). El uso del producto hace necesarios conocimientos profundos y conocimientos parciales del idioma inglés. Por eso se deberá tener en cuenta de exclusivamente autorizar para el uso del producto a personas peritas o debidamente minuciosamente instruidas con los conocimientos citados. Si fuera necesaria indumentaria de seguridad para el uso de productos de R&S, encontrará la información debida en la documentación del producto en el capítulo correspondiente.

Símbolos y definiciones de seguridad

Ver documentación de producto	Informaciones para maquinaria con un peso de > 18kg	Peligro de golpe de corriente	¡Advertencia! Superficie caliente	Conexión a conductor protector	Conexión a tierra	Conexión a masa conductora	¡Cuidado! Elementos de construcción con peligro de carga electrostática

potencia EN MARCHA/PARADA	Indicación Stand-by	Corriente continua DC	Corriente alterna AC	Corriente continua/alterna DC/AC	El aparato está protegido en su totalidad por un aislamiento de doble refuerzo

Informaciones de seguridad

Tener en cuenta las informaciones de seguridad sirve para tratar de evitar daños y peligros de toda clase. Es necesario de que se lean las siguientes informaciones de seguridad concienzudamente y se tengan en cuenta debidamente antes de la puesta en funcionamiento del producto. También deberán ser tenidas en cuenta las informaciones para la protección de personas que encontrarán en el capítulo correspondiente de la documentación de producto y que también son obligatorias de seguir. En las informaciones de seguridad actuales hemos juntado todos los objetos vendidos por el grupo de empresas Rohde & Schwarz bajo la denominación de „producto“, entre ellos también aparatos, instalaciones así como toda clase de accesorios.

Palabras de señal y su significado

PELIGRO	Identifica un peligro directo con riesgo elevado de provocar muerte o lesiones de gravedad si no se toman las medidas oportunas.
ADVERTENCIA	Identifica un posible peligro con riesgo medio de provocar muerte o lesiones (de gravedad) si no se toman las medidas oportunas.
ATENCIÓN	Identifica un peligro con riesgo reducido de provocar lesiones de gravedad media o leve si no se toman las medidas oportunas.
CUIDADO	Indica la posibilidad de utilizar mal el producto y a consecuencia dañarlo.
INFORMACIÓN	Indica una situación en la que deberían seguirse las instrucciones en el uso del producto, pero que no consecuentemente deben de llevar a un daño del mismo.

Las palabras de señal corresponden a la definición habitual para aplicaciones civiles en el área económica europea. Pueden existir definiciones diferentes a esta definición en otras áreas económicas o en aplicaciones militares. Por eso se deberá tener en cuenta que las palabras de señal aquí descritas sean utilizadas siempre solamente en combinación con la correspondiente documentación de producto y solamente en combinación con el producto correspondiente. La utilización de las palabras de señal en combinación con productos o documentaciones que no les correspondan puede llevar a malinterpretaciones y tener por consecuencia daños en personas u objetos.

Informaciones de seguridad elementales

1. El producto solamente debe ser utilizado según lo indicado por el fabricante referente a la situación y posición de funcionamiento sin que se obstruya la ventilación. Si no se convino de otra manera, es para los productos R&S válido lo que sigue: como posición de funcionamiento se define principalmente la posición con el suelo de la caja para abajo, modo de protección IP 2X, grado de suciedad 2, categoría de sobrecarga eléctrica 2, utilizar solamente en estancias interiores, utilización hasta 2000 m sobre el nivel del mar, transporte hasta 4.500 m sobre el nivel del mar. A menos que se especifique otra cosa en la hoja de datos, se aplicará una tolerancia de $\pm 10\%$ sobre el voltaje nominal y de $\pm 5\%$ sobre la frecuencia nominal.
2. En todos los trabajos deberán ser tenidas en cuenta las normas locales de seguridad de trabajo y de prevención de accidentes. El producto solamente debe de ser abierto por personal perito autorizado. Antes de efectuar trabajos en el producto o abrirlo deberá este ser desconectado de la corriente. El ajuste, el cambio de partes, la manutención y la reparación deberán ser solamente efectuadas por electricistas autorizados por R&S. Si se reponen partes con importancia para los aspectos de seguridad (por ejemplo el enchufe, los transformadores o los fusibles), solamente podrán ser sustituidos por partes originales. Después de cada recambio de partes elementales para la seguridad deberá ser efectuado un control de seguridad (control a primera vista, control de conductor protector, medición de resistencia de aislamiento, medición de medición de la corriente conductora, control de funcionamiento).

Informaciones de seguridad

3. Como en todo producto de fabricación industrial no puede ser excluido en general de que se produzcan al usarlo elementos que puedan generar alergias, los llamados elementos alergénicos (por ejemplo el níquel). Si se produjeran en el trato con productos R&S reacciones alérgicas, como por ejemplo urticaria, estornudos frecuentes, irritación de la conjuntiva o dificultades al respirar, se deberá consultar inmediatamente a un médico para averiguar los motivos de estas reacciones.
4. Si productos / elementos de construcción son tratados fuera del funcionamiento definido de forma mecánica o térmica, pueden generarse elementos peligrosos (polvos de sustancia de metales pesados como por ejemplo plomo, berilio, níquel). La partición elemental del producto, como por ejemplo sucede en el tratamiento de materias residuales, debe de ser efectuada solamente por personal especializado para estos tratamientos. La partición elemental efectuada inadecuadamente puede generar daños para la salud. Se deben tener en cuenta las directivas nacionales referentes al tratamiento de materias residuales.
5. En el caso de que se produjeran agentes de peligro o combustibles en la aplicación del producto que debieran de ser transferidos a un tratamiento de materias residuales, como por ejemplo agentes refrigerantes que deben ser repuestos en periodos definidos, o aceites para motores, deberán ser tenidas en cuenta las prescripciones de seguridad del fabricante de estos agentes de peligro o combustibles y las regulaciones regionales para el tratamiento de materias residuales. Cuiden también de tener en cuenta en caso dado las prescripciones de seguridad especiales en la descripción del producto.
6. Ciertos productos, como por ejemplo las instalaciones de radiación HF, pueden a causa de su función natural, emitir una radiación electromagnética aumentada. En vista a la protección de la vida en desarrollo deberían ser protegidas personas embarazadas debidamente. También las personas con un bypass pueden correr peligro a causa de la radiación electromagnética. El empresario/usuario está comprometido a valorar y señalar áreas de trabajo en las que se corra un riesgo aumentado de exposición a radiaciones para evitar riesgos.
7. La utilización de los productos requiere instrucciones especiales y una alta concentración en el manejo. Debe de ponerse por seguro de que las personas que manejen los productos estén a la altura de los requerimientos necesarios referente a sus aptitudes físicas, psíquicas y emocionales, ya que de otra manera no se pueden excluir lesiones o daños de objetos. El empresario lleva la responsabilidad de seleccionar el personal usuario apto para el manejo de los productos.
8. Antes de la puesta en marcha del producto se deberá tener por seguro de que la tensión preseleccionada en el producto equivalga a la de la red de distribución. Si es necesario cambiar la preselección de la tensión también se deberán en caso de cambio cambiar los fusibles correspondientes del producto.
9. Productos de la clase de seguridad I con alimentación móvil y enchufe individual de producto solamente deberán ser conectados para el funcionamiento a tomas de corriente de contacto de seguridad y con conductor protector conectado.
10. Queda prohibida toda clase de interrupción intencionada del conductor protector, tanto en la toma de corriente como en el mismo producto. Puede tener como consecuencia el peligro de golpe de corriente por el producto. Si se utilizaran cables o enchufes de extensión se deberá poner al seguro, que es controlado su estado técnico de seguridad.
11. Si el producto no está equipado con un interruptor para desconectarlo de la red, se deberá considerar el enchufe del cable de distribución como interruptor. En estos casos deberá asegurarse de que el enchufe sea de fácil acceso y nabejo (según la medida del cable de distribución, aproximadamente 2 m). Los interruptores de función o electrónicos no son aptos para el corte de la red eléctrica. Si los productos sin interruptor están integrados en construcciones o instalaciones, se deberá instalar el interruptor al nivel de la instalación.

Informaciones de seguridad

12. No utilice nunca el producto si está dañado el cable eléctrico. Compruebe regularmente el correcto estado de los cables de conexión a red. Asegure a través de las medidas de protección y de instalación adecuadas de que el cable de eléctrico no pueda ser dañado o de que nadie pueda ser dañado por él, por ejemplo al tropezar o por un golpe de corriente.
13. Solamente está permitido el funcionamiento en redes de distribución TN/TT aseguradas con fusibles de como máximo 16 A (utilización de fusibles de mayor amperaje sólo previa consulta con el grupo de empresas Rohde & Schwarz).
14. Nunca conecte el enchufe en tomas de corriente sucias o llenas de polvo. Introduzca el enchufe por completo y fuertemente en la toma de corriente. Si no tiene en consideración estas indicaciones se arriesga a que se originen chispas, fuego y/o heridas.
15. No sobrecargue las tomas de corriente, los cables de extensión o los enchufes de extensión ya que esto pudiera causar fuego o golpes de corriente.
16. En las mediciones en circuitos de corriente con una tensión de entrada de $U_{\text{eff}} > 30 \text{ V}$ se deberá tomar las precauciones debidas para impedir cualquier peligro (por ejemplo medios de medición adecuados, seguros, limitación de tensión, corte protector, aislamiento etc.).
17. En caso de conexión con aparatos de la técnica informática se deberá tener en cuenta que estos cumplan los requisitos de la EC950/EN60950.
18. A menos que esté permitido expresamente, no retire nunca la tapa ni componentes de la carcasa mientras el producto esté en servicio. Esto pone a descubierto los cables y componentes eléctricos y puede causar heridas, fuego o daños en el producto.
19. Si un producto es instalado fijamente en un lugar, se deberá primero conectar el conductor protector fijo con el conductor protector del aparato antes de hacer cualquier otra conexión. La instalación y la conexión deberán ser efectuadas por un electricista especializado.
20. En caso de que los productos que son instalados fijamente en un lugar sean sin protector implementado, autointerruptor o similares objetos de protección, el circuito de suministro de corriente deberá estar protegido de manera que usuarios y productos estén suficientemente protegidos.
21. Por favor, no introduzca ningún objeto que no esté destinado a ello en los orificios de la caja del aparato. No vierta nunca ninguna clase de líquidos sobre o en la caja. Esto puede producir corto circuitos en el producto y/o puede causar golpes de corriente, fuego o heridas.
22. Asegúrese con la protección adecuada de que no pueda originarse en el producto una sobrecarga por ejemplo a causa de una tormenta. Si no se verá el personal que lo utilice expuesto al peligro de un golpe de corriente.
23. Los productos R&S no están protegidos contra el agua si no es que exista otra indicación, ver también punto 1. Si no se tiene en cuenta esto se arriesga el peligro de golpe de corriente para el usuario o de daños en el producto lo cual también puede llevar al peligro de personas.
24. No utilice el producto bajo condiciones en las que pueda producirse y se hayan producido líquidos de condensación en o dentro del producto como por ejemplo cuando se desplaza el producto de un lugar frío a un lugar caliente.
25. Por favor no cierre ninguna ranura u orificio del producto, ya que estas son necesarias para la ventilación e impiden que el producto se caliente demasiado. No pongan el producto encima de materiales blandos como por ejemplo sofás o alfombras o dentro de una caja cerrada, si esta no está suficientemente ventilada.
26. No ponga el producto sobre aparatos que produzcan calor, como por ejemplo radiadores o calentadores. La temperatura ambiental no debe superar la temperatura máxima especificada en la hoja de datos.

Informaciones de seguridad

27. Baterías y acumuladores no deben de ser expuestos a temperaturas altas o al fuego. Guardar baterías y acumuladores fuera del alcance de los niños. No cortocircuitar baterías ni acumuladores. Si las baterías o los acumuladores no son cambiados con la debida atención existirá peligro de explosión (atención celulas de Litio). Cambiar las baterías o los acumuladores solamente por los del tipo R&S correspondiente (ver lista de piezas de recambio). Las baterías y acumuladores deben reutilizarse y no deben acceder a los vertederos. Las baterías y acumuladores que contienen plomo, mercurio o cadmio deben tratarse como residuos especiales. Respete en esta relación las normas nacionales de evacuación y reciclaje.
28. Por favor tengan en cuenta que en caso de un incendio pueden desprenderse del producto agentes venenosos (gases, líquidos etc.) que pueden generar daños a la salud.
29. El producto puede poseer un peso elevado. Muévelo con cuidado para evitar lesiones en la espalda u otras partes corporales.
30. No sitúe el producto encima de superficies, vehículos, estantes o mesas, que por sus características de peso o de estabilidad no sean aptas para él. Siga siempre las instrucciones de instalación del fabricante cuando instale y asegure el producto en objetos o estructuras (por ejemplo paredes y estantes).
31. Las asas instaladas en los productos sirven solamente de ayuda para el manejo que solamente está previsto para personas. Por eso no está permitido utilizar las asas para la sujeción en o sobre medios de transporte como por ejemplo grúas, carretillas elevadoras de horquilla, carros etc. El usuario es responsable de que los productos sean sujetados de forma segura a los medios de transporte y de que las prescripciones de seguridad del fabricante de los medios de transporte sean tenidas en cuenta. En caso de que no se tengan en cuenta pueden causarse daños en personas y objetos.
32. Si llega a utilizar el producto dentro de un vehículo, queda en la responsabilidad absoluta del conductor que conducir el vehículo de manera segura. Asegure el producto dentro del vehículo debidamente para evitar en caso de un accidente las lesiones u otra clase de daños. No utilice nunca el producto dentro de un vehículo en movimiento si esto pudiera distraer al conductor. Siempre queda en la responsabilidad absoluta del conductor la seguridad del vehículo. El fabricante no asumirá ninguna clase de responsabilidad por accidentes o colisiones.
33. Dado el caso de que esté integrado un producto de laser en un producto R&S (por ejemplo CD/DVD-ROM) no utilice otras instalaciones o funciones que las descritas en la documentación de producto. De otra manera pondrá en peligro su salud, ya que el rayo laser puede dañar irreversiblemente sus ojos. Nunca trate de descomponer estos productos. Nunca mire dentro del rayo laser.

Safety Instructions for Instruments with Fold-Out Feet



WARNING

Danger of injury

The feet may fold in if they are not folded out completely or if the instrument is shifted. The feet may break if they are overloaded.

Fold the feet completely in or completely out to ensure stability of the instrument and personal safety.

To avoid injuries, never shift the instrument when its feet are folded out.

The overall load (the instrument's own weight plus that of the instruments stacked on top of it) on the folded-out feet must not exceed 500 N.

Place the instrument on a stable surface. Secure the instruments stacked on top of it against slipping (e.g. by locking their feet on the top front frame).

When the instrument is standing on its folded-out feet, do not work under the instrument and do not put anything under it, otherwise injuries or material damage could occur.

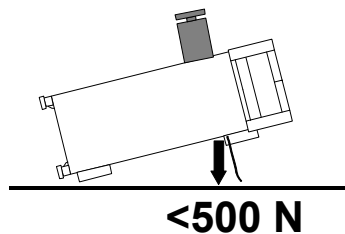

The instrument can be used in each of the positions shown here.

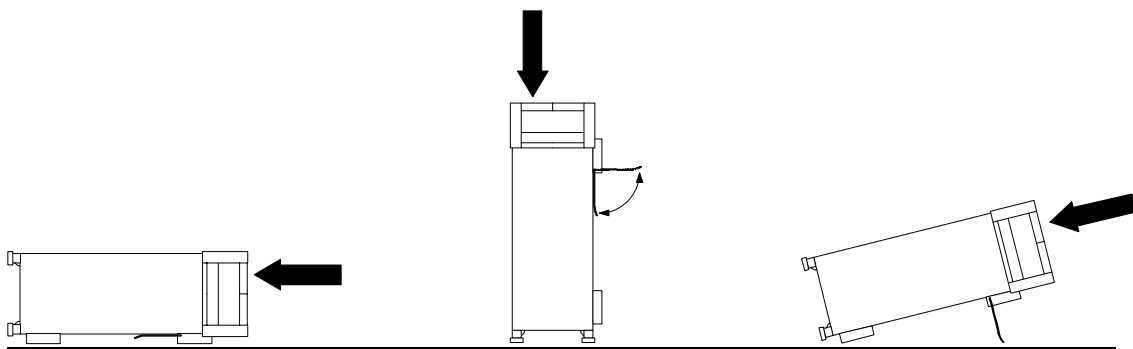

Informaciones de seguridad para aparatos con telepiés



ADVERTENCIA

Peligro de heridas

Los telepiés pueden doblarse hacia adentro si no han sido desdoblados por completo o si el aparato es movido. Los telepiés pueden romperse si son sobrecargados.

Doblar los telepiés por completo hacia afuera o hacia adentro. De esta manera se puede asegurar la estabilidad del aparato y a la vez la seguridad de las personas.

No mover nunca el aparato con los telepiés desdoblados, para evitar heridas.

El peso total equilibrado (peso propio más el de los aparatos posicionados sobre este) ejercido sobre los telepiés no deberá exceder a los 500N.

Posicionar el aparato sobre una superficie estable. Los aparatos puestos encima de éste deben estar asegurados para que no resbalen (por ejemplo fijando los pies del aparato en el listón del marco de delante arriba).

Por favor no manipulen debajo del aparato y no pongan nada debajo de este cuando esté posicionado sobre los telepiés desdoblados, ya que si no pueden originarse heridas o daños en objetos.

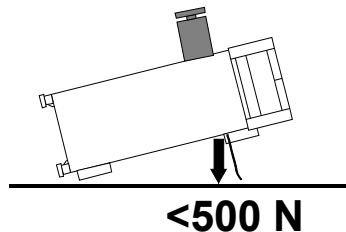

El aparato puede ser puesto en funcionamiento en cualquiera de las posiciones aquí descritas.

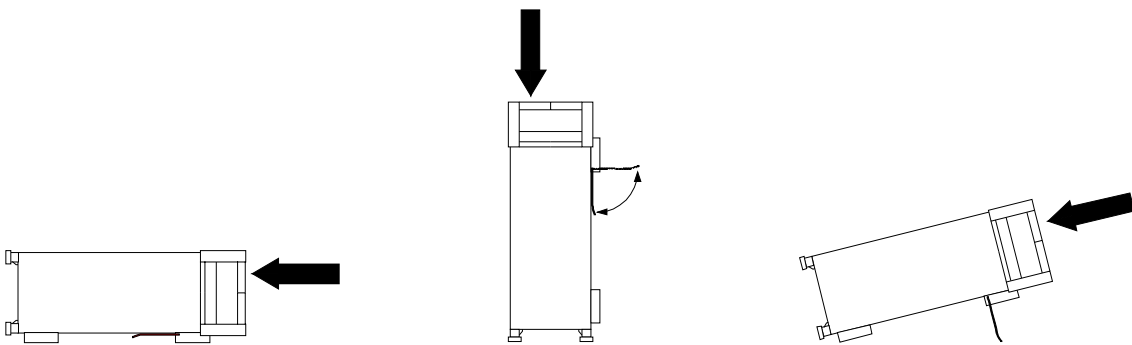

Safety Instructions for Stacking Instruments



WARNING

Danger of injury

Instruments may slip if they are stacked on top of each other.

Place the instrument on a stable, even surface. Stack the instruments according to their size, with the largest instrument on the bottom. Do not stack more than three instruments directly on top of each other. Instruments may only be stacked if their feet and housing allow horizontal stacking. If these conditions are not met, the instruments must be installed in a rack in order to avoid the risk of personal injury and material damage.

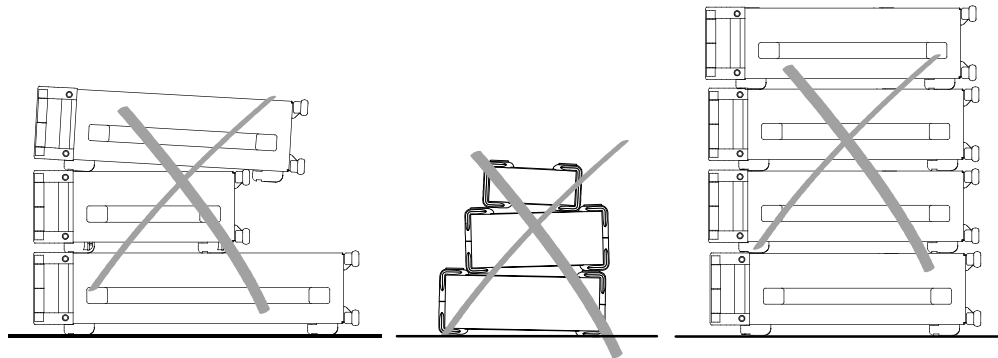
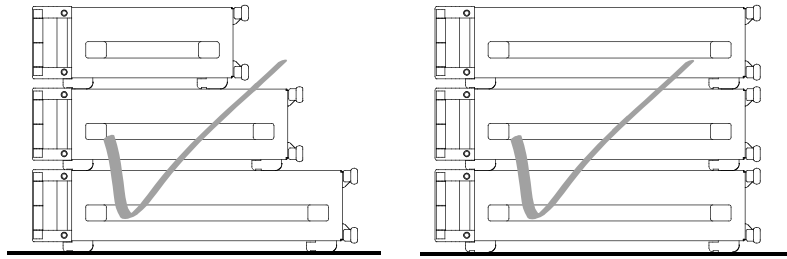

Incorrect order

Incompatible feet

Too many instruments stacked

Informaciones de seguridad para el amontonamiento de aparatos



ADVERTENCIA

Peligro de heridas

Los aparatos pueden desplazarse al ser amontonados.

Posicionar los aparatos sobre una superficie estable y lisa. Amontonar los aparatos por orden de su tamaño. No amontonar nunca más de tres aparatos uno sobre el otro. Los aparatos solamente deberán ser amontonados, si los pies y la caja del aparato correspondiente hacen posible amontonarlos de forma horizontal. Si no se cumplen estas condiciones, deberán ser montados los aparatos en una caja apta para este propósito. De esta manera evitarán el riesgo de daños en personas y daños en el aparato.

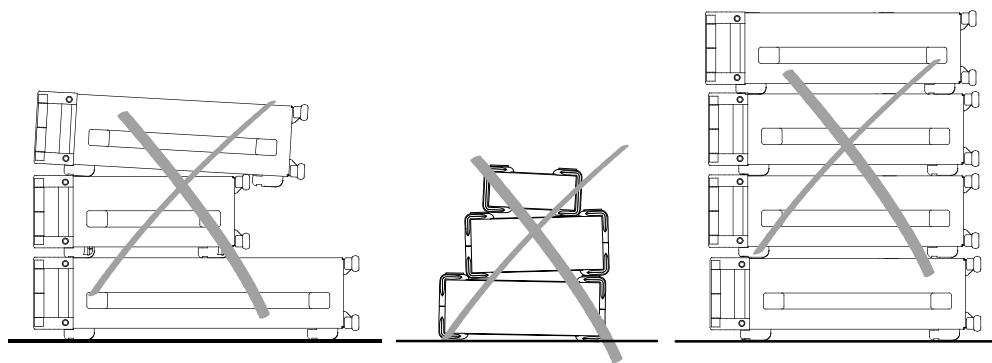
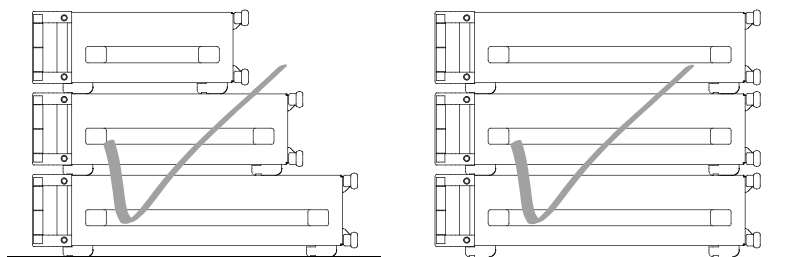

orden no permitido

piés incompatibles

demasiados aparatos amontonados



ROHDE & SCHWARZ
EC Certificate of Conformity



Certificate No.: 99042

This is to certify that:

Equipment type	Order No.	Designation
SMR20	1104.0002.20	Signal Generator 1 to 20 GHz
SMR27	1104.0002.27	Signal Generator 1 to 27 GHz
SMR30	1104.0002.30	Signal Generator 1 to 30 GHz
SMR40	1104.0002.40	Signal Generator 1 to 40 GHz
SMR-B1	1104.5485.02	Option: Reference Oscillator OCXO
SMR-B5	1104.3501.02/.03	Option: AM/FM/SCAN Modulator
SMR-B11	1104.4250.02	Option: Frequency Extension
SMR-B15	1104.4989.02	Option: RF Attenuator 20 GHz
SMR-B17	1104.5233.02	Option: RF Attenuator 40 GHz
SMR-B19	1104.6281.02	Option: Rear Connector
SMR-B20	1104.6381.02	Option: Rear Connector
SMR-B23	1104.5804.02	Option: IF Input 20 GHz

complies with the provisions of the Directive of the Council of the European Union on the approximation of the laws of the Member States

- relating to electrical equipment for use within defined voltage limits
(73/23/EEC revised by 93/68/EEC)
- relating to electromagnetic compatibility
(89/336/EEC revised by 91/263/EEC, 92/31/EEC, 93/68/EEC)

Conformity is proven by compliance with the following standards:

EN61010-1 : 1993 + A2 : 1995
EN50081-1 : 1992
EN50082-2 : 1995

Affixing the EC conformity mark as from 1999

ROHDE & SCHWARZ GmbH & Co. KG
Mühldorfstr. 15, D-81671 München

Munich, 2000-08-24

Central Quality Management FS-QZ / Becker

Certified Quality System

DIN EN ISO 9001 : 2000

DIN EN 9100 : 2003

DIN EN ISO 14001 : 1996

DQS REG. NO 001954 QM/ST UM

QUALITÄTSZERTIFIKAT

Sehr geehrter Kunde,

Sie haben sich für den Kauf eines Rohde & Schwarz-Produktes entschieden. Hiermit erhalten Sie ein nach modernsten Fertigungsmethoden hergestelltes Produkt. Es wurde nach den Regeln unseres Managementsystems entwickelt, gefertigt und geprüft.

Das Rohde & Schwarz Managementsystem ist zertifiziert nach:

DIN EN ISO 9001:2000
DIN EN 9100:2003
DIN EN ISO 14001:1996

CERTIFICATE OF QUALITY

Dear Customer,

you have decided to buy a Rohde & Schwarz product. You are thus assured of receiving a product that is manufactured using the most modern methods available. This product was developed, manufactured and tested in compliance with our quality management system standards.

The Rohde & Schwarz quality management system is certified according to:

DIN EN ISO 9001:2000
DIN EN 9100:2003
DIN EN ISO 14001:1996

CERTIFICAT DE QUALITÉ

Cher Client,

vous avez choisi d'acheter un produit Rohde & Schwarz. Vous disposez donc d'un produit fabriqué d'après les méthodes les plus avancées. Le développement, la fabrication et les tests respectent nos normes de gestion qualité.

Le système de gestion qualité de Rohde & Schwarz a été homologué conformément aux normes:

DIN EN ISO 9001:2000
DIN EN 9100:2003
DIN EN ISO 14001:1996



ROHDE & SCHWARZ

Customer Support

Technical support – where and when you need it

For quick, expert help with any Rohde & Schwarz equipment, contact one of our Customer Support Centers. A team of highly qualified engineers provides telephone support and will work with you to find a solution to your query on any aspect of the operation, programming or applications of Rohde & Schwarz equipment.

Up-to-date information and upgrades

To keep your Rohde & Schwarz equipment always up-to-date, please subscribe to our electronic newsletter at

<http://www.rohde-schwarz.com/www/response.nsf/newsletterpreselection>

or request the desired information and upgrades via email from your Customer Support Center (addresses see below).

Feedback

We want to know if we are meeting your support needs. If you have any comments please email us and let us know CustomerSupport.Feedback@rohde-schwarz.com.

USA & Canada

Monday to Friday (except US public holidays)

8:00 AM – 8:00 PM Eastern Standard Time (EST)

Tel. from USA 888-test-rsa (888-837-8772) (opt 2)

From outside USA +1 410 910 7800 (opt 2)

Fax +1 410 910 7801

E-mail Customer.Support@rsa.rohde-schwarz.com

East Asia

Monday to Friday (except Singaporean public holidays)

8:30 AM – 6:00 PM Singapore Time (SGT)

Tel. +65 6 513 0488

Fax +65 6 846 1090

E-mail Customersupport.asia@rohde-schwarz.com

Rest of the World

Monday to Friday (except German public holidays)

08:00 – 17:00 Central European Time (CET)

Tel. from Europe +49 (0) 180 512 42 42

From outside Europe +49 89 4129 13776

Fax +49 (0) 89 41 29 637 78

E-mail CustomerSupport@rohde-schwarz.com



Contents of User Documentation for Microwave Signal Generator R&S SMR

The user documentation describes the Mikrowave-Signal Generator R&S SMR and all options. It includes a printed Quick Start Guide and a CD-ROM with the complete operating and service manual in printable pdf-format.

Der R&S SMR selbst ist mit einer kontextsensitiven Online-Hilfe ausgestattet, die zu jeder Gerätefunktion eine Hilfeseite anbietet.

Quick Start Guide



The present quick start guide describes everything that is needed to put the instrument into operation and to get familiar with the generator. The quick start guide gives an introduction to remote control and manual control via external monitor, mouse and keyboard.

The quick start guide is subdivided into the data sheet plus 3 chapters plus index:

The data sheet informs about specifications and characteristics of the instrument.

Chapter 1 Describes the control elements and connectors on the front and rear panel as well as all procedures required for putting the instrument into operation.

Chapter 2 Gives an introduction the operating concept and typical applications of the R&S SMA.

Chapter 3 Describes key operating modes, the structure of the graphical interface and the principles of manual control.

Chapter 4 Contains an index for the quick start guide.

Help System



The help system is embedded in the instrument, offering quick, context-sensitive reference to the information needed for operation and programming. The help contains the complete user documentation for the R&S SMR including the contents of the present quick start guide.

Documentation CD-ROM

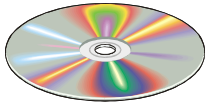

The CD-ROM provides the complete user documentation for the Signal Generator:

- The complete operating manual and service manual in printable form (*.pdf).
 - The data sheet (brochure and specifications) in printable form.
- Links to different useful sites in the R&S internet.

Optional Documentation

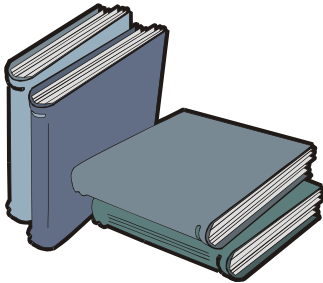

Operating Manual

The operating manual contains comprehensive information about the instrument functions and remote control, in addition to the chapters of the quick start guide. It includes information about maintenance of the instrument and about error detection listing the error messages which may be output by the instrument. It is subdivided into 10 chapters:

- Chapter 1** describes the control elements and connectors on the front and rear panel as well as all procedures required for putting the instrument into operation.
- Chapter 2** gives an introduction to the operating concept and typical applications of the R&S SMR.
- Chapter 3** describes key operating modes, the structure of the graphical interface and the principles of manual control.
- Chapter 4** forms a reference for manual control of the R&S SMR and contains a detailed description of all instrument functions and their application. The chapter also lists the remote control command corresponding to each instrument function.
- Kapitel 5** describes the basics for programming the R&S SMR, command processing and the status reporting system.
- Chapter 6** lists all the remote-control commands defined for the instrument.
- Chapter 7** contains program examples for a number of typical applications of the R&S SMR.
- Chapter 8** describes preventive maintenance and the characteristics of the instrument's interfaces.
- Chapter 9** gives the status messages and a list of error messages that the R&S SMR may generate.
- Chapter 10** contains an index for the operating manual.

Service Manual Instrument

The service manual - instrument informs on how to check compliance with rated specifications, on instrument function, repair, troubleshooting and fault elimination. It contains all information required for the maintenance of R&S SMR by exchanging modules. In addition it describes how to perform a firmware update and how to install options.

1 Putting into Operation

This chapter contains all information about putting into operation (unpacking, connection to AC supply, switching on and off), functional testing and installation of the instrument, preset settings and views of the front and rear panel showing the controls and connectors needed for operation.

General Instructions

Before putting the SMR into operation, please make sure that

- the covers of the casing are put on and screwed,
- the ventilation openings are free,
- no signal voltage levels exceeding the permissible limits are applied at the inputs,
- the outputs of the instrument are not overloaded or connected incorrectly.

If these points are not observed, the instrument might be damaged.

Unpacking the Instrument

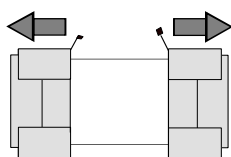

remove protective caps

- Take the instrument out of the shipping box and check whether the items listed in the packing list and in the lists of accessories are all included.
- Remove the two protective caps from the front and rear of the SMR and carefully check the instrument for damage.

Should the instrument be damaged, immediately notify the forwarder who shipped the instrument to you and keep the box and packing material.

For further transport or shipment of the SMR the original packing should also be used. It is recommended to keep at least the two protective caps for front and rear side in order to prevent damage to the controls and connectors.

Setting up the Instrument

For applications in the laboratory or on a work bench, it is recommended that the support feet on the bottom of the instrument be extended. For the LCD display, this provides the optimum viewing angle which typically ranges from perpendicular to the display front to approximately 30° below.

WARNING



The feet must be fully folded in or out. Only in this way can the stability of SML be guaranteed and reliable operation be ensured. With the feet out, the weight of other units put onto SML must not exceed 30 kg. The units must be secured against slipping (eg by locking the feet of the unit at the top side of the enclosure).

When shifting the unit with the feet out, the feet might collapse and fold in. To avoid injuries, the unit must therefore not be shifted with the feet out.

Supply Voltage

The SMR can be operated at a.c. systems from 100 to 120 V and 200 to 240 V at system frequencies from 50 to 60 Hz. The power supply socket is situated at the rear of the instrument. The instrument automatically sets itself to the voltage applied within the permissible voltage ranges. It is not necessary to set the instrument to a certain supply voltage.

How to Ensure EMC

In order to avoid electromagnetic interference, the instrument may only be operated when it is closed and with all shielding covers fitted. Only appropriate shielded signal and control cables may be used.

Power Fuses

The SMR is protected against short circuits by means of two fuses according to nameplate of the power supply. The fuses are situated in the draw-out fuse holder which is inserted close to the power supply socket (see below).



—— Power supply socket

—— Fuse holder

Power supply socket at the rear of the instrument

Switching On/Off the Instrument

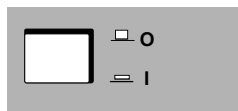

Switch on:

- Press switch.
- The instrument is ready for operation.

Switch off:

- Release switch.

On/Off switch at the front of the instrument

Initial Status

Upon switching on, the instrument automatically assumes the status which was set when it was switched off.

If the instrument need not to be operated from the initial status any further, a defined default status should be established by pressing the [PRESET] key prior to further settings.

Frequency accuracy after switching on when the oven-controlled reference oscillator is fitted (option SMR-B1)

The reference oscillator needs some minutes of warm-up time to reach its nominal frequency. During this period of time, the output frequency does not yet reach its final value either. In the status line in the header field of the display the message "OVEN COLD" is displayed for this time.

RAM With Battery Back-Up

The SMR has a static read-write memory (CMOS-RAM) with battery back-up, in which 50 different complete settings of the instrument can be stored (cf. Chapter 3, section "Storing and Calling of

Instrument Settings"). In addition, all data and/or lists the user enters himself, such as for list mode, memory sequence, and user correction of the level, are stored in the RAM. Further, all data of the calibrations running within the instrument in the SMR are stored in the RAM (cf. Chapter 4, section "Calibration" and Service Manual Instrument). A lithium battery with a service life of approx. 5 years serves to supply the RAM with power. When the battery is discharged, the data stored will be lost. Exchanging the battery is described in the Service Manual Instrument.

Preset Setting

A defined setting status is achieved by pressing the [PRESET] key.

Preset Status:

RF frequency	10 GHz
RF level	-20 dBm
Reference frequency	internal, adjustment off
Offsets	0
Modulations	switched off
Transient-free level setting	switched off, level attenuator mode: Auto
Internal level control	level Alc: On
User correction	level Ucor: Off
LF output	switched off
Sweep	switched off
List mode	switched off
Memory sequence	switched off
Suppression of indications	system security: unaltered
Protection of calibration data	protection lock: unaltered
Settings stored	unaltered
Data, lists etc. stored	unaltered
IEC-bus address	unaltered

All parameters and circuit states, even those of operating modes which are not activated, are preset by means of Preset. The presettings going beyond the above list can be seen from the menu representations as of Chapter 4 which each indicate the Preset setting status.

Functional Test

On switching on the instrument and permanently during operation, the SMR carries out a self test. The ROM contents as well as the battery of the non-volatile RAM are checked. The most important instrument functions are automatically monitored during operation. If an error is detected, the message "Err" is displayed in the status line. For further identification of the error, press the [ERROR] key. Thereupon a description of the error is displayed (cf. Chapter 9, section "Error Messages"). Return to the menu exited by pressing the [BACK] key. If required, internal test points can be polled by the user and the results be read out and displayed. Cf. Service Manual Instrument.

Mounting into a 19" Rack

CAUTION



Ensure free air inlet at the perforation of the side walls and air outlet at the rear of the instrument in rack mounting.

The SMR can be mounted into a 19" rack by means of rack adapter ZZA-94 (stock no. 396.4905.00). The mounting instructions are attached to the adapter.

Explanation of Front and Rear Panel

Elements of the Front Panel

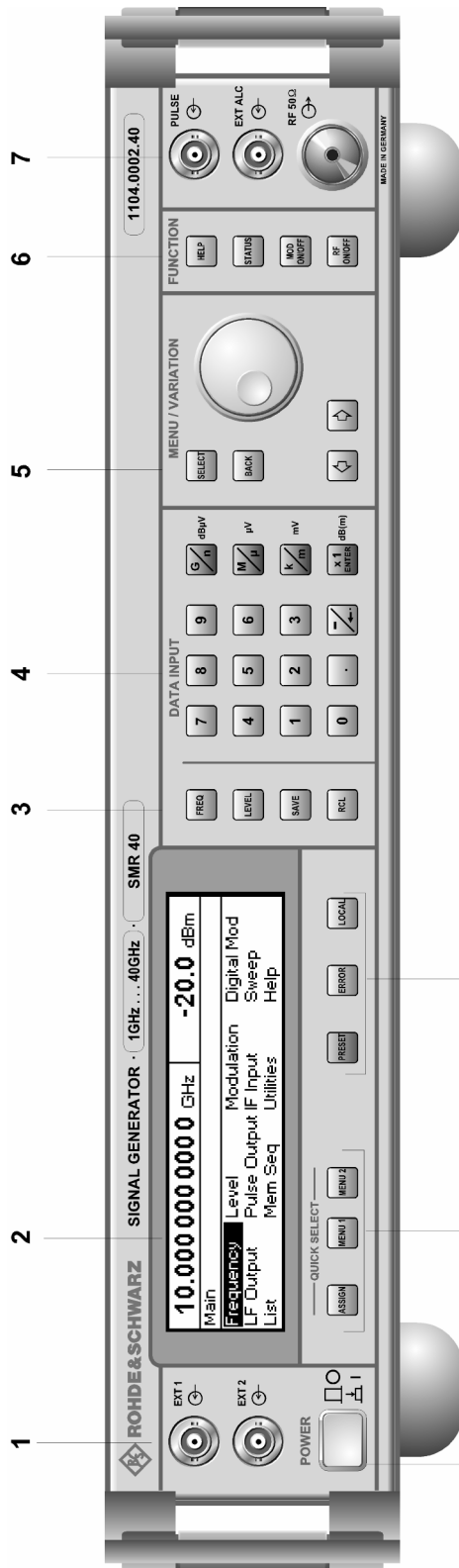

Fig. 1-1 Front panel view

1



- EXT1 Input external modulation signal alternatively for AM, FM, ASK and FSK.
- EXT2 Input external modulation signal alternatively for AM and FM.
- PULSE Input for triggering the pulse generator or for direct control of the pulse modulation.

2 DISPLAY

Cf. Chapter 3 for the design of the display.

3

Parameter field



Parameters RF frequency and RF level can be entered directly by means of the parameter keys, alternatively to menu operation. Further, complete instrument settings can be stored and called.

- FREQ Opens the setting of the RF frequency via value input or variation by means of a rotary knob. The current menu is maintained. Return to the menu by means of the [BACK] key. (Setting of the RF frequency also in the FREQUENCY menu).
- LEVEL Opens the setting of the RF level via value input or variation by means of a rotary knob. The current menu is maintained. Return to the menu by means of the [BACK] key. (Setting of the RF level also in the LEVEL menu).
- SAVE Opens the storing of the current instrument setting. Memory selection is effected by entering a number (1 to 50) and is finished by means of the [x1/ENTER] key.
- RCL Opens the calling of an instrument setting stored. Memory selection is effected by entering a number (1 to 50) and is finished by means of the [x1/ENTER] key.

⇒ Cf. Chapter 3, Sections "Use of [FREQ] and [LEVEL] Keys", "RF Frequency", "RF Level" and "Storing and Calling of Instrument Settings".

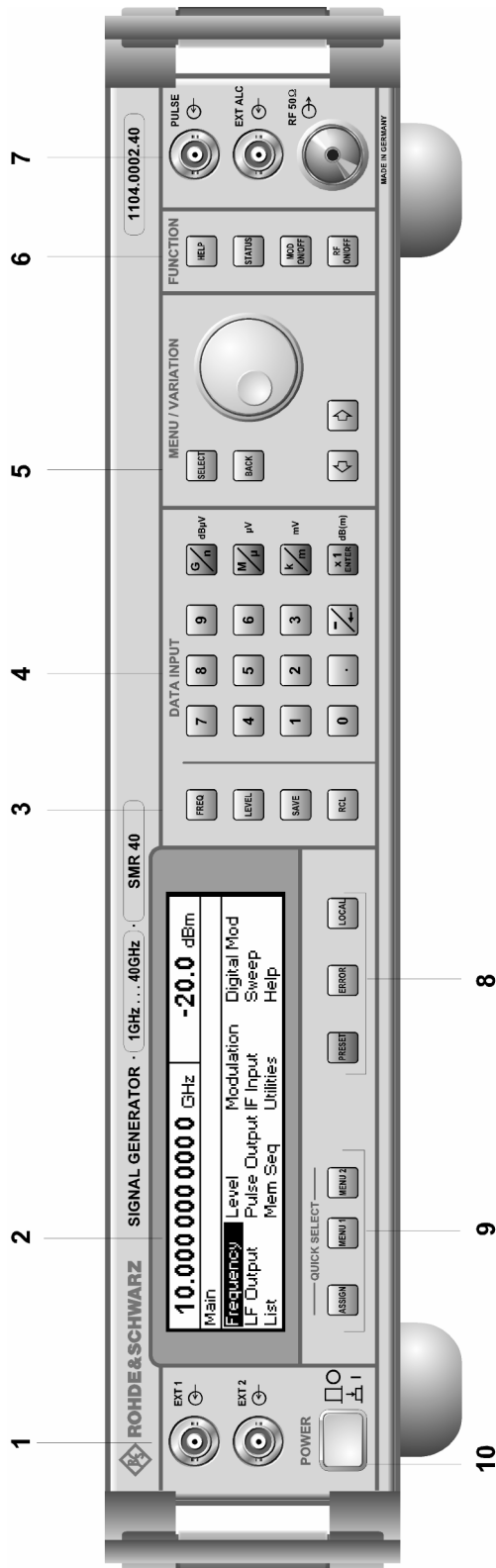
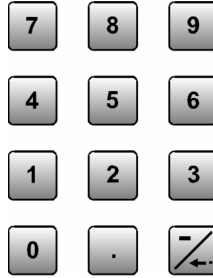

Fig. 1-1 Front panel view

4 DATA INPUT

Numeric input field



Numeric values, decimal point and minus sign can be entered by means of the digital keys.

- 0...9 Enters the digit.
- . Enters the decimal point
- /← Enters the minus sign.
Deletes the last input (digit, sign or decimal point) - key [BACKSPACE]

Unit keys with enter function



The unit keys terminate the input of values and specify the multiplication factor for the respective basic unit.

The basic units are displayed next to the input field while numbers are entered. In the case of level settings, the unit keys specify the unit.

- G/n dBμV Selects giga/nano, with RF level dBμV.
- M/μ μV Selects mega/micro, with level μV.
- k/m mV Selects kilo/milli, with level mV.
- 1x Enter dB(m) Terminates entries in the basic unit and value inputs without unit.
Selects with level dBm.
Selects with level offset and level step width dB.

In order to change to another level unit, simply press the unit key desired. Parameter LEVEL must be activated, e.g. by pressing the [LEVEL] key.

⇒ Cf. Chapter 3, Section "Change Unit of Level".

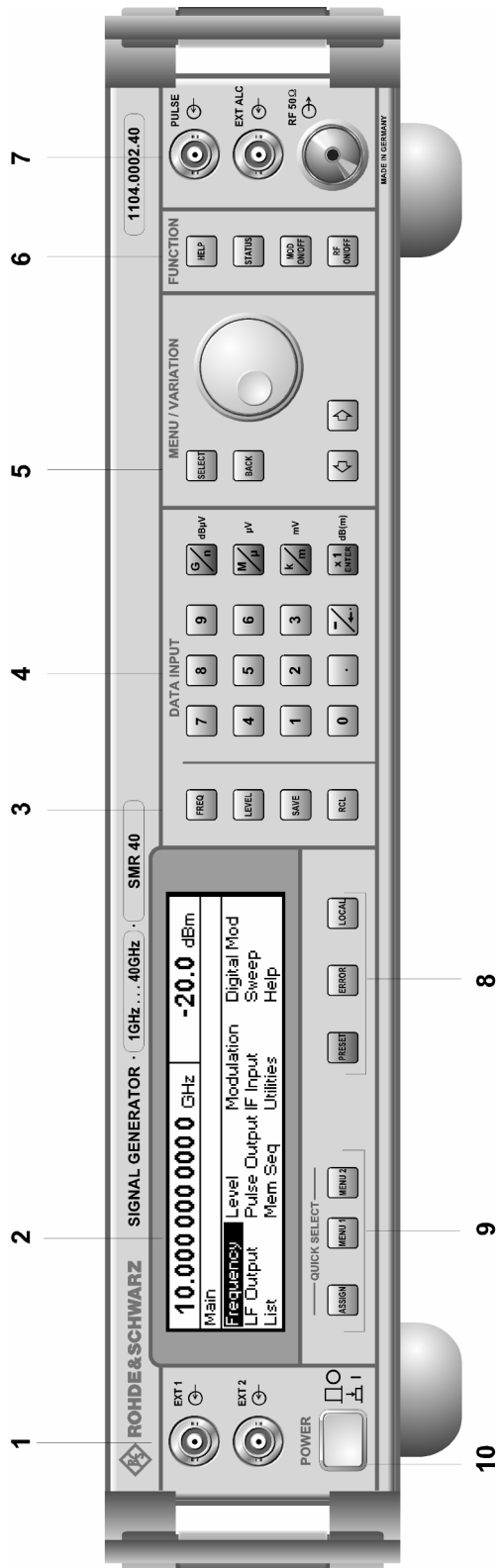
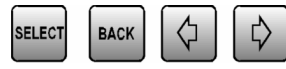

Fig. 1-1 Front panel view

5 MENU/VARIATION



Menu keys

The menu keys access the menus and settings within the menus.

SELECT Acknowledges the choice marked by the menu cursor.

BACK Returns the menu cursor to the next higher menu level.

⇐ Moves the digit cursor to the left by one position in the marked value indication. Moves the menu cursor to the left by one position in a 1-out-of-n selection.

⇒ Moves the digit cursor to the right by one position in the marked value indication. Moves the menu cursor to the right by one position in a 1-out-of-n selection.

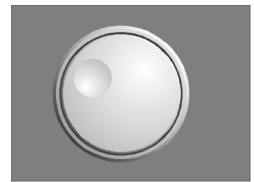

8 Rotary knob

The rotary knob moves the menu cursor over the positions of a menu level to choose from, or varies the value of a parameter. The variation is either effected in steps of one or in a step width that can be specified at will.

Furthermore, by pressing the rotary knob when the cursor marks a menu position, the lower menu level or the setting menu is displayed (cf. function of [SELECT] key).

⇒ Cf. Chapter 2, Section "Sample Setting for First Users" and Chapter 3, Section "Basic Operating Steps".

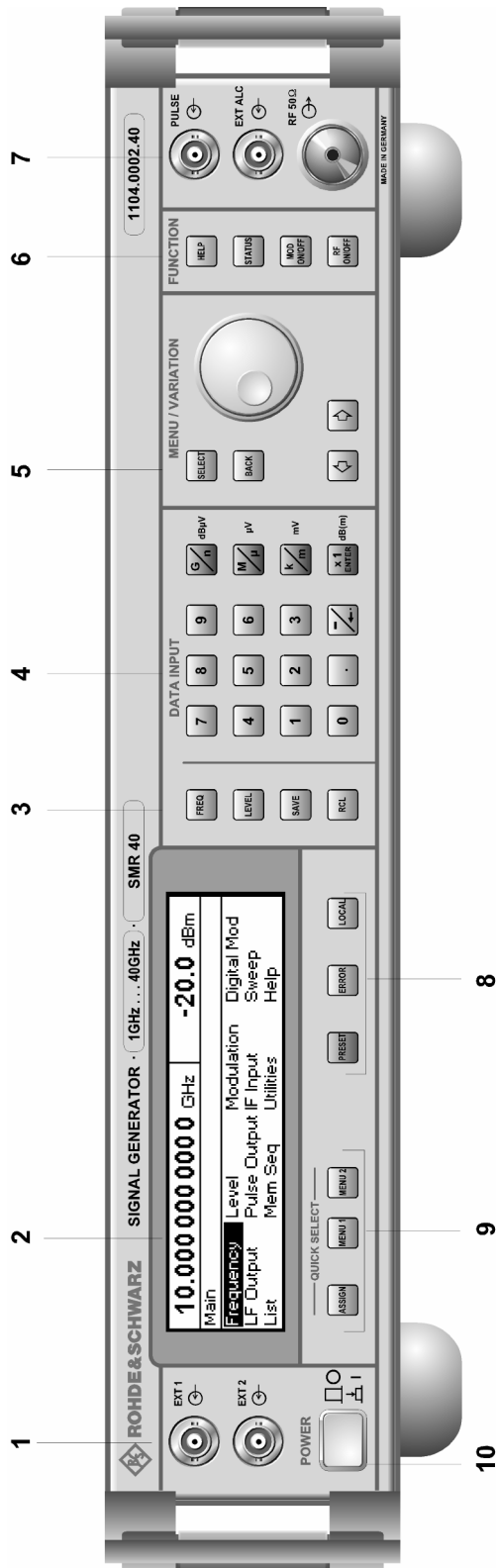

Fig. 1-1 Front panel view

6 FUNCTION



- HELP* Indicates context-sensitive auxiliary text.
- STATUS* Indicates the instrument status.
- MOD ON/OFF Switches on/off the modulation selected in Utilities - ModKey.
- RF ON/OFF Switches on/off the RF signal.

⇒ Cf. Chapter 4, Sections "The Help System", "Status", and Chapter 3, Section "Use of [MOD ON/OFF] and [RF ON/OFF] keys".

* Exit the menus using the [BACK] key.

7



- LF Output LF signal of the internal LF-generator.
- PULSE/VIDEO Output of pulse generator or video output (only with Option SMR-B14).
- EXT ALC Input detection voltage of an external level detector.

⇒ Cf. Chapter 4, Section "Switch On/Off Internal Level Control", Section "Pulse Modulation" and Section "[RF ON/OFF] Key".

8



- PRESET Establishes a defined instrument status.
- ERROR* Indicates error and caution messages.
- LOCAL Switches the instrument from the REMOTE mode (remote control) to the LOCAL mode (manual control).

⇒ Cf. Chapter 1, Section "Preset Settings", Chapter 9, "Error Messages" and Chapter 6, "Remote Control".

* Exit the menus using the [BACK] key.

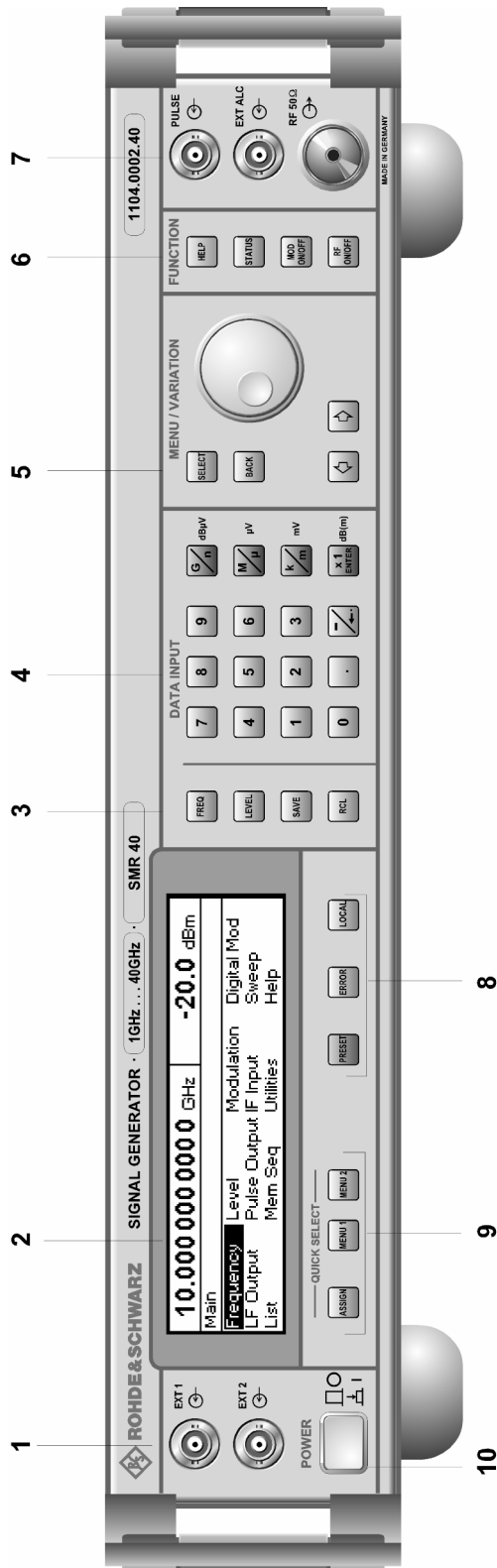

Fig. 1-1 Front panel view

9 QUICK SELECT



The menu-quick-selection keys permit fast access to two menus selected.

ASSIGN Stores the current menu as menu1 when the MENU1 key is pressed afterwards or as menu2 when the MENU2 key is pressed afterwards.

MENU1 Activates menu1 stored.

MENU2 Activates menu2 stored.

⇒ Cf. Chapter 3, Section "Quick Selection of Menu (QUICK SELECT)".

10 ON/OFF SWITCH

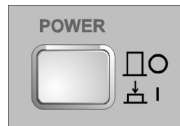

The On/Off switch switches the instrument on ("I") or off ("O").

⇒ Cf. Chapter 1, Section "Switching On/Off the Instrument".

Elements of the Rear Panel

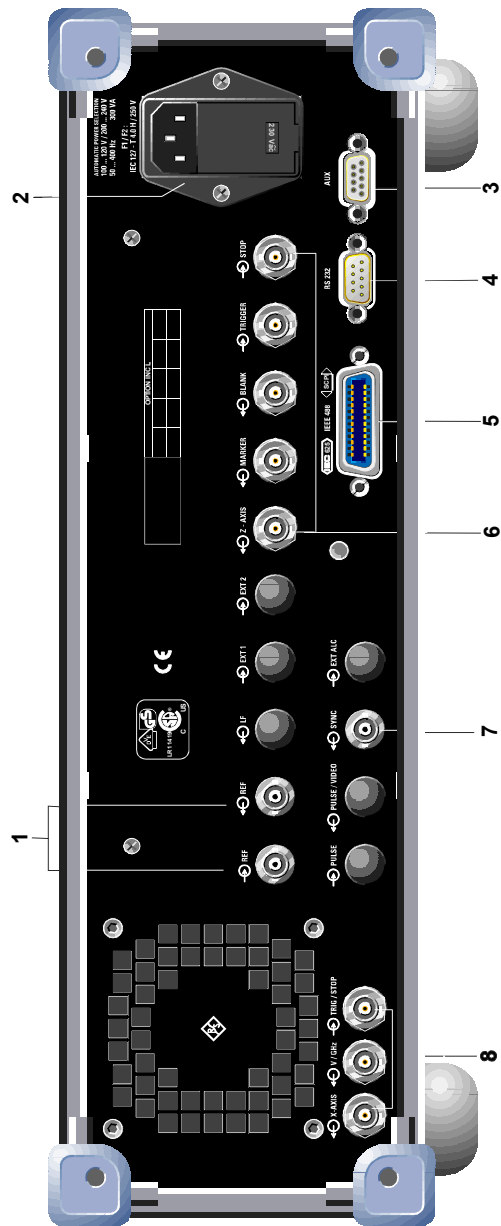

1



REF Output of the internal 10-MHz-reference signal with reference internal.
 Input for external reference frequency 10 MHz with reference external. LF Output LF signal of the internal LF-generator. LF Output LF signal of the internal LF-generator.

⇒ Cf. Chapter 4, Sections "LF Output" and "Internal/External Reference Frequency (REF OSC)".

2

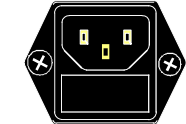

Power supply connector and fuse holder

⇒ Cf. Chapter 1, Section "Power Fuses".

3 AUX

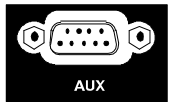

Interface for direct control of additional, external devices.

Pin	Designation	Assignment
1	MARKER	Marker signal output for sweep mode.
2	BLANK	Blanking signal input for sweep mode.
3	TRIGGER	Trigger input for sweep, memory sequence and list modes.
4	STOP	Input for stopping the sweep.
5	Z-AXIS	combined MARKER/BLANK signal.
6 - 9	GROUND	

Fig. 1-2 Rear panel view

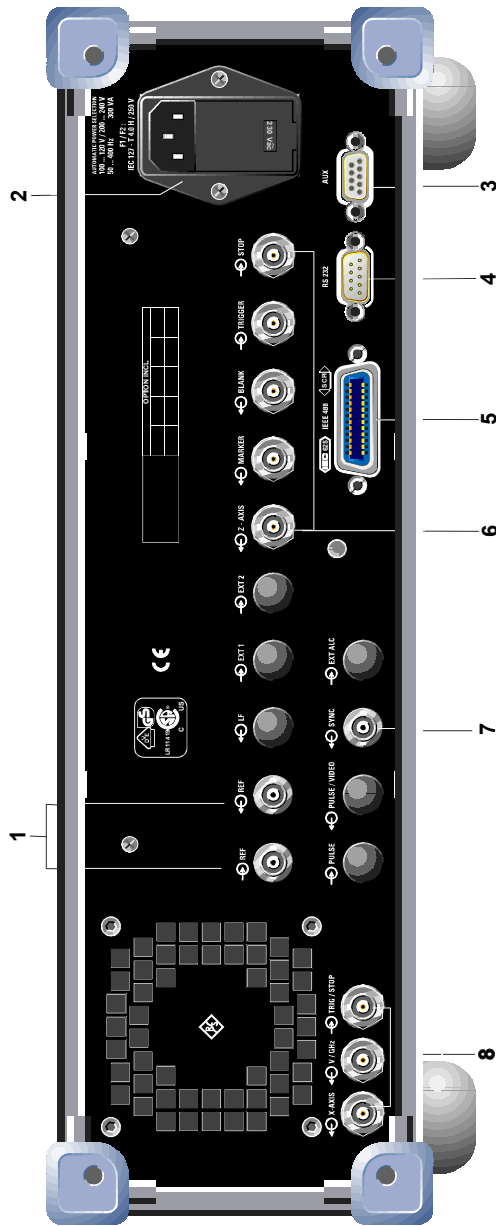

4

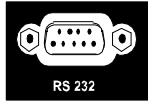

RS-232 RS-232-C interface used for software update and remote control. The pin assignment corresponds to the pin assignment of a PC.

⇒ Cf. Chapter 5, Section "Interface RS-232-C".

5

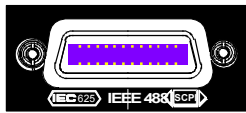

IEC 625 IEC-bus (IEEE 488)
IEEE 488 Interface for Remote Control

⇒ Cf. Chapter 5 "Remote Control".

6



MARKER Marker signal output for sweep mode.
BLANK Blanking signal input for sweep mode.
TRIGGER Trigger input for sweep, memory sequence and list modes.
STOP Input for stopping the sweep.
Z-AXIS combined MARKER/BLANK signal.

Fig. 1-2 Rear panel view

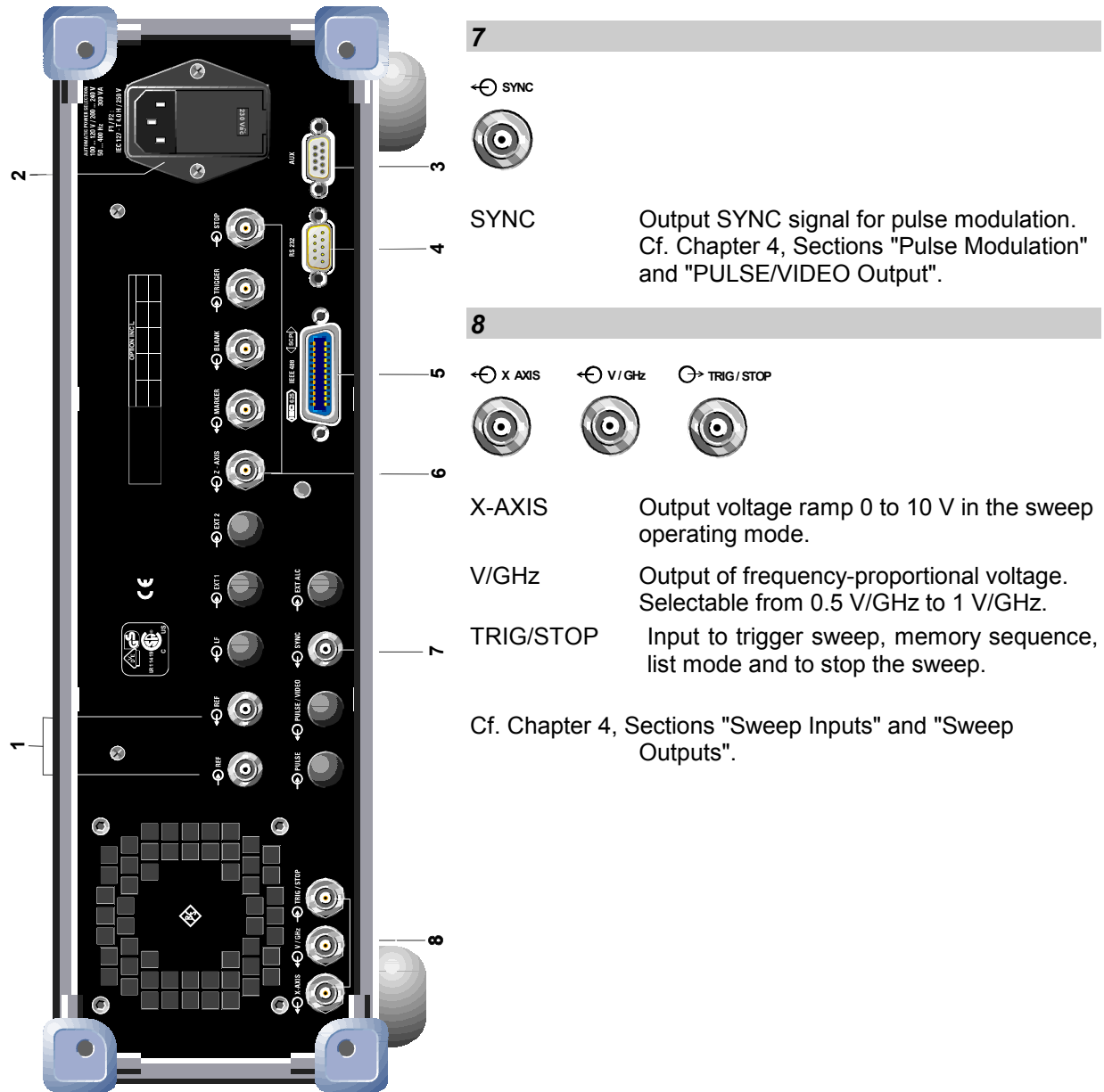

7

← SYNC



SYNC

Output SYNC signal for pulse modulation. Cf. Chapter 4, Sections "Pulse Modulation" and "PULSE/VIDEO Output".

8

← X AXIS ← V / GHz → TRIG / STOP



X-AXIS

Output voltage ramp 0 to 10 V in the sweep operating mode.

V/GHz

Output of frequency-proportional voltage. Selectable from 0.5 V/GHz to 1 V/GHz.

TRIG/STOP

Input to trigger sweep, memory sequence, list mode and to stop the sweep.

Cf. Chapter 4, Sections "Sweep Inputs" and "Sweep Outputs".

Fig. 1-2 Rear panel view

2 Short Tutorial

The present chapter contains a short tutorial with sample settings allowing the users to operate immediately the instrument.

Sample Setting for First Users

Setting frequency and level of the RF output signal

First frequency and level of the RF output signal are set via keys [FREQ] and [LEVEL] in the DATA INPUT field:







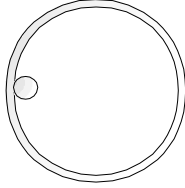

- frequency 2.5 GHz
- level 10 dBm

Operating steps	Explanations
<p style="text-align: center;">MENU / VARIATION</p> <div style="display: flex; justify-content: space-around; align-items: center;"> <div style="border: 1px solid black; padding: 5px; width: 40px; text-align: center;">PRESET</div> <div style="border: 1px solid black; padding: 5px; width: 40px; text-align: center;">SELECT</div> </div>	<p>Reset the instrument to the defined state.</p>
<p style="text-align: center;">DATA INPUT</p> <div style="display: flex; align-items: center; gap: 10px;"> <div style="border: 1px solid black; padding: 5px; width: 40px; text-align: center;">FREQ</div> <div style="border: 1px solid black; padding: 5px; width: 30px; text-align: center;">2</div> <div style="border: 1px solid black; padding: 5px; width: 30px; text-align: center;">.</div> <div style="border: 1px solid black; padding: 5px; width: 30px; text-align: center;">5</div> <div style="border: 1px solid black; padding: 5px; width: 30px; text-align: center;">G n</div> <div style="margin-left: 20px;">[dBμV]</div> </div>	<p>Set the frequency to 2.5 GHz. The menu cursor marks the permanent frequency indication.</p>
<p style="text-align: center;">DATA INPUT</p> <div style="display: flex; align-items: center; gap: 10px;"> <div style="border: 1px solid black; padding: 5px; width: 40px; text-align: center;">LEVEL</div> <div style="border: 1px solid black; padding: 5px; width: 30px; text-align: center;">1</div> <div style="border: 1px solid black; padding: 5px; width: 30px; text-align: center;">0</div> <div style="border: 1px solid black; padding: 5px; width: 30px; text-align: center;">x1 ENTER</div> <div style="margin-left: 20px;">dB(m)</div> </div>	<p>Set the level to 10 dBm. The menu cursor marks the permanent level indication.</p>
<div style="border: 1px solid black; padding: 5px; width: 40px; text-align: center; margin-left: 10px;">BACK</div>	<p>Reset the menu cursor to the menu field.</p>

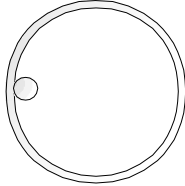
AM modulation of the output signal

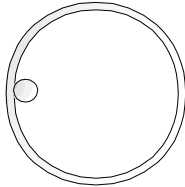
The output signal is to be amplitude-modulated next.

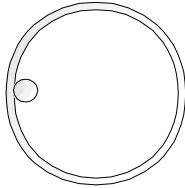
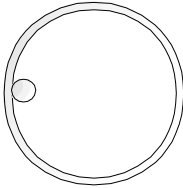
- AM modulation depth 30 %
- AM signal 1-kHz sine

Operating steps		Explanations
<p>MENU / VARIATION</p>  <p style="text-align: center;">· Modulation ·</p>	<p>MENU / VARIATION</p> 	<p>Select menu Modulation using rotary knob.</p> <p>Press [SELECT] key or rotary knob. The submenu is displayed.</p>
<p>MENU / VARIATION</p>  <p style="text-align: center;">· AM ·</p>	<p>MENU / VARIATION</p> 	<p>Select submenu AM.</p> <p>Press [SELECT] key or rotary knob. The AM setting menu is displayed.</p>
<p>MENU / VARIATION</p>  <p style="text-align: center;">· AM Depth ·</p>	<p>MENU / VARIATION</p> 	<p>Select parameter AM Depth using rotary knob.</p> <p>Press [SELECT] key or rotary knob. The menu cursor marks the setting value.</p>
<p>DATA INPUT</p> 		<p>Enter modulation depth 30 % and acknowledge using [x1/Enter] key.</p>
<p>BACK</p> 		<p>Reset menu cursor to AM Depth using [BACK] key.</p>
<p>MENU / VARIATION</p>  <p style="text-align: center;">· AM Source ·</p>	<p>MENU / VARIATION</p> 	<p>Select AM Source using rotary knob.</p> <p>Press [SELECT] key or rotary knob. A pop-up menu displays the current 1-out-of-n selection.</p>

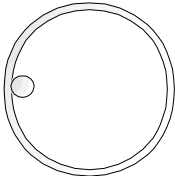
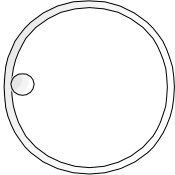
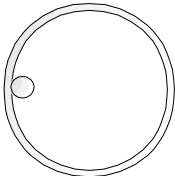





Operating steps	Explanations
<p>MENU / VARIATION</p>  <p style="text-align: center;">· LFGen ·</p> <p>MENU / VARIATION</p> <p style="text-align: center;">SELECT</p>	<p>Select LF generator as modulation source using rotary knob.</p> <p>The selection mark marks LFGen.</p> <p>Press [SELECT] key or rotary knob. The cursor is set back to AM Source.</p>
<p>BACK</p>	<p>Press [BACK] key.</p>
<p>MENU / VARIATION</p>  <p style="text-align: center;">· LFGen Freq ·</p> <p>MENU / VARIATION</p> <p style="text-align: center;">SELECT</p>	<p>Select parameter LFGen Freq using rotary knob.</p> <p>Press [SELECT] key or rotary knob. The menu cursor marks the current frequency selection.</p>
<p>MENU / VARIATION</p>  <p style="text-align: center;">· 1k ·</p> <p>MENU / VARIATION</p> <p style="text-align: center;">SELECT</p>	<p>Set the frequency of the LF generator to 1 kHz.</p> <p>The selection mark marks 1 kHz. Press [SELECT] key or rotary knob. The AM modulation setting is completed.</p> <p>The indications on the display are represented in Fig. 2-1.</p>

10.0000000000 GHz	-20.0 dBm
Modulation/AM	
AM Depth	30.0 %
AM Source	Off
Scan State	Off
Ext1 Coupling	AC
Ext2 Coupling	AC
Ext1 Impedance	100 kΩ
Ext2 Impedance	100 kΩ
Lfgen Freq	1.0000 kHz
Lfgen Shape	Sin
Back ↵	

Fig. 2-1 Display for AM setting

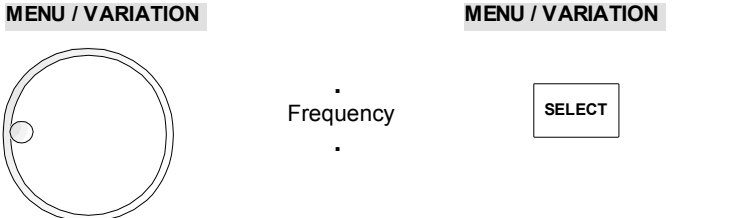
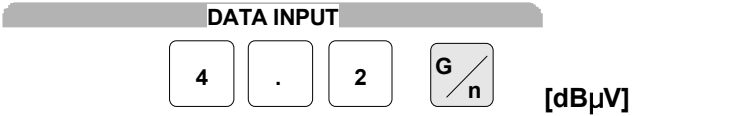
Setting the step width

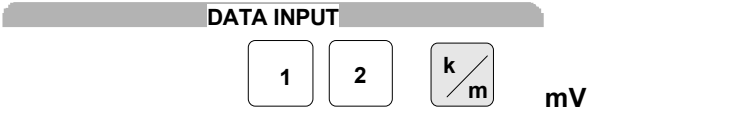
Subsequently to the above setting, 4.2 GHz as new RF frequency and 12 kHz as the step width for the RF frequency variation are set in the following.

Operating steps	Explanations
	Reset the menu cursor to the main menu in 3 steps.
	Select menu Frequency using rotary knob. Press [SELECT] key or rotary knob. The frequency setting menu is displayed.
	Select parameter Frequency. Press [SELECT] key or rotary knob. The menu cursor marks the setting value.
	Enter frequency 4.2 GHz. Press [SELECT] key or rotary knob. The menu cursor is set back to Frequency.
	Press [BACK] key. The menu cursor is set back to Frequency.
	Select parameter Knob Step User using rotary knob. Press [SELECT] key or rotary knob.
	Enter step width 12 kHz.
	Press [BACK] key. The menu cursor is set back to Knob Step User.

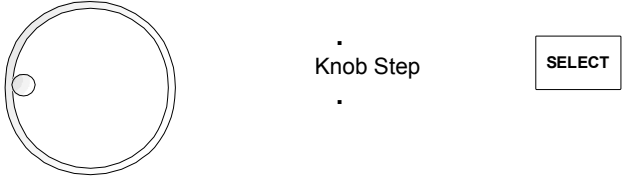
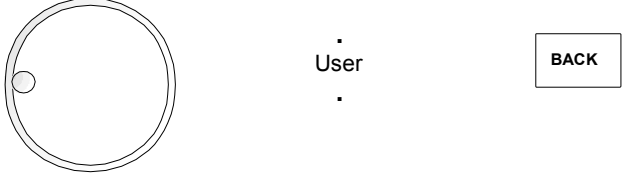
Operating steps	Explanations
<p>MENU / VARIATION</p>  <p>MENU / VARIATION</p> <p>Knob Step</p> <p>SELECT</p>	<p>Select parameter Knob Step using rotary knob. Press [SELECT] key or rotary knob.</p> <p>A pop-up menu displays the available settings.</p>
<p>MENU / VARIATION</p>  <p>MENU / VARIATION</p> <p>User</p> <p>BACK</p>	<p>Select User (user-defined step width) using rotary knob.</p> <p>This results in step width 12 kHz being used in the case of variation using the rotary knob.</p> <p>Press [BACK] key. The menu cursor is set back to Knob Step.</p>

10.000000000 GHz	-20.0 dBm
Frequency	
Frequency	10.000000000 GHz
Offset	0.0 Hz
Multiplier	1.0
Knob Step User	12.0000 KHz
Knob Step	User
Exclude from Recall	Off
Back ↵	

Fig. 2-2 Display after pattern setting

3 Manual Operation

This chapter shows the design of the display and describes the manual control of the microwave signal generator, for example calling up of menus, selection and editing of parameters, use of the list editor and the SAVE/RECALL function. This chapter also contains an overview of menus showing the functions available for the instruments and its options.

It is useful to read the sample settings for first users in Chapter 2, "Short Tutorial".

Design of the Display

(1)	10.000 000 0000 GHz		-20.0 dBm	
(2)	Main			
(3)	Frequency	Level	Modulation	Digital Mod
	LF Output	Pulse Output	Sweep	List
	Utilities	Help		

Fig. 3-1 Design of the display

(1) Header field The header field of the display indicates frequency and level of the RF output signal. In the RF-sweep operating mode, the start and stop frequencies are displayed in two lines one above the other. The start and stop levels are indicated in the LEVEL-sweep operating mode correspondingly. With User Correction On, the current frequency and the corresponding correction value are indicated in two lines.

(2) Status line The status line indicates at the left the menu path of the current menu and at the right the operating mode and operating state of the instrument. Error messages and notes for caution are also displayed in the status line.

(3) Menu fields The indication fields below the status line are reserved for the menu representations. The image contents of these fields change as a function of the menu selected.

The lowest menu level shows the setting menu with the current settings of the selected menu. Settings are made in select or input windows which open when the current setting is activated.

Menu cursor The menu cursor shows the user at which position in the menu he is. The position of the menu cursor is evident from the inverse notation of the term (white characters on a black background).

Digit cursor As a bright field, the digit cursor marks the position which can be varied by means of the rotary knob in a value indication.

Basic Operating Steps

To operate the instrument, menus are called in the display. All setting possibilities and the current setting status are evident from the menus. All settings can be made by accessing the menus. RF frequency and RF level can also be set without menu operation using keys [FREQ] and [LEVEL]. RF signal and modulation can also be switched on/off without menu operation using keys [RF ON/OFF] and/or [MOD ON/OFF].

Calling the menus

Accessing the menus is effected using rotary knob [VARIATION], [SELECT] key and [BACK] key.

Rotary knob Rotary knob [VARIATION] moves the menu cursor over the positions of a menu level to be selected. If a scrollbar is visible at the right-hand margin of a menu, the menu is larger than the screen window. If the menu cursor is moved to the margin of the screen window, the covered lines become visible.

If the rotary knob is pressed after a position has been selected, the lower menu level or the respective settings are called. The rotary knob hence has the same function as the [SELECT] key.

If the rotary knob is pressed while [BACK] is selected, the menu cursor wraps back to the menu last called.

[SELECT] key The [SELECT] key acknowledges the selection marked by means of the menu cursor. Depending on the position, the next lower menu level or the the respective setting is called.

[BACK] key The [BACK] key

- returns the menu cursor to the next higher menu level; the menu cursor is shifted to the left into the preceding column of the menu structure,
- resets the menu cursor from frequency or level value indication in the header field into the menu field to the menu called last,
- closes the display pages called using keys [STATUS], [HELP] and [ERROR] again.

Settings are accessed in the setting menus ending with the right-hand display margin.

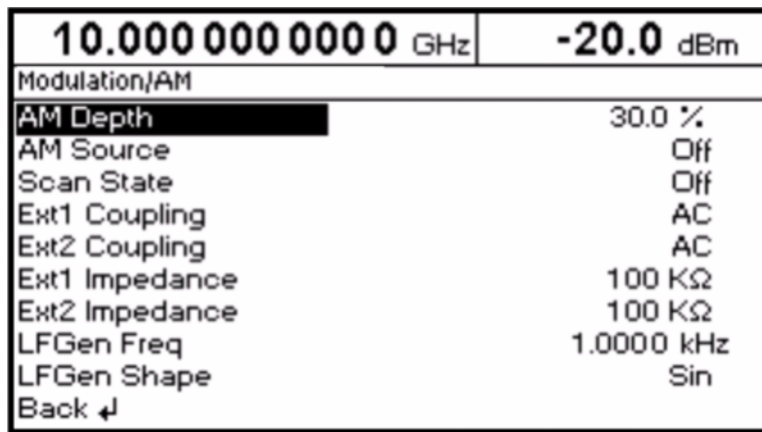

Fig. 3-2 Modulation - AM Menu

Selection and Change of Parameters

Select parameter ➤ Set the menu cursor to the name of the parameter desired using the rotary knob, e.g. to AM Depth in the AM menu, cf. Fig. 3-2.

Change setting value ➤ Select parameter.
➤ Press [SELECT] key or rotary knob.
The menu cursor changes from the parameter selected in the left-hand column of the setting menu to the setting value on the right, e.g. from AM Depth to 30%, cf. Fig. 3-2.

Via value inputs ➤ Press the first digit of the new value or minus sign.
The old value is deleted, the entry is indicated in the marked field.
➤ Enter further digits.
➤ Terminate the input using a unit key or, in the case of inputs in the base unit or in the case of inputs without unit, using the [1x/Enter] key.
➤ Press [BACK] key or mark selection BACK using rotary knob and then press rotary knob.
The menu cursor wraps back to the appropriate parameter.

Using rotary knob ➤ Set the digit cursor (bright field) to the position of the setting value to be varied using keys [⇒] [⇐].
➤ Turn rotary knob.
The value is varied in steps of 1.

Note: *RF frequency and RF level can also be varied in a step width which can be defined arbitrarily, using the rotary knob. In the respective setting menu (Frequency or Level), the step width is entered as Knob Step User and the Knob Step set from Decimal to User. To point to the fact that the step width has been converted to the value programmed, the bright field as a symbol of the digit cursor disappears in the respective value indication.*

- 1-out-of-n selection**
- Select parameter.
 - Press [SELECT] key or rotary knob.
A pop-up menu displays a selection of settings.
 - Set the menu cursor to the position desired within the 1-out-of-n selection using the rotary knob or cursor keys [←] [→].
 - Press [SELECT] key or rotary knob.
The setting is made.
The pop-up menu is closed and the current setting is indicated at the right margin of the display.
 - Press [BACK] key or mark selection BACK using rotary knob and then press rotary knob.

The menu cursor wraps back to the next higher menu level.

Quick Selection of Menu (QUICK SELECT)

The keys of the QUICK SELECT control field are used to call selected menus quickly by one keystroke.

- Store menus**
- Establish the desired operating status of the current menu.
 - Press [ASSIGN] key.
 - Press [MENU1] or [MENU2] key.
The current menu is stored as menu1 or menu2. That is to say, 2 menus can be stored in total.
- Call menus**
- Press [MENU1] or [MENU2] key.
Menu1 or menu2 stored is displayed. Exactly the operating status which was current at the point of time of storing is reconstructed.

Use of [FREQ] and [LEVEL] Keys

RF frequency and RF level can be set without menu operation as well using direct keys [FREQ] and [LEVEL].

- [FREQ] / [LEVEL] keys**
- Press [FREQ] or [LEVEL] key.
The frequency or the level indication in the header field of the display is marked. The current menu at the display is maintained.
 - Alter the value via a value input or the rotary knob.
 - Press [BACK] key or rotary knob.
The menu cursor wraps to the position marked last in the menu.

Use of [RF ON/OFF] and [MOD ON/OFF]

RF signal and modulation can be switched on/off without menu operation as well using keys [RF ON/OFF] and/or [MOD ON/OFF] (cf. Sections "[RF ON/OFF] Key" and "[MOD ON/OFF] Key").

- [RF ON/OFF] key**
- Press [RF ON/OFF] key.
The RF output signal is switched on/off.
IEC/IEEE-bus short command: `:OUTP:STAT ON`

- [MOD ON/OFF] key**
- Press [MOD ON/OFF] key.
Modulation is switched on/off.
A direct IEC-bus command is not available. The modulations have to be switched on and off in the respective modulation submenus.

Changing Unit of Level

For the level, the unit of the value set can be changed without a new value input.

- Change level unit**
- Activate Level parameter.
 - Press [LEVEL] key or
 - set menu cursor in the level menu to the setting value of the Amplitude parameter.
 - Press the unit key with with the desired level unit.
The level is indicated in the desired unit.

Correction of Input

Digits can be corrected by one of the following keys before the input is confirmed by the [Enter] key:

- Key [-/←]** The backspace key deletes the value entered digit by digit. When the last digit is deleted, the previous value is displayed.
- [BACK] key** Pressing the [BACK] key deletes the entire entry and results in the previous value being indicated again.
- For a subsequent new input in the setting menu, the menu cursor is to be set to the setting value again using the [SELECT] key.
- For a subsequent new input via the [FREQ] or [LEVEL] keys, the respective key has to be pressed again.
- [FREQ]/[LEVEL] keys** In the case of a frequency or level input by means of the [FREQ] or [LEVEL] keys, pressing the [FREQ] and/or [LEVEL] key again deletes the entire input.

List Editor

The SMR offers the facility of generating lists for automatic sequences (list mode, memory sequence) or for user-defined level correction (Ucor). The lists consist of elements (pairs of values) which are defined by an index and at least one parameter per index. Each list is assigned a separate name and selected by means of this name. Access to the lists is made in the associated menus. For example, sequences of frequency and level value pairs can be accessed in the List menu. How to generate and edit lists is explained in detail in this section by the example of the List mode (List menu, see Fig. 3-3).

Menu selection: List

10.000 000 0000 GHz		-20.0 dBm	
List			
Mode		Off	
Reset List			
Dwell		15.0 ms	
Current Index		1	
Select List		List0	
Delete List			
Edit List		Insert	
Attenuator Mode		Auto	
Atten Fixed Range		-35.0 dBm to unlevelled	
Back	↵		

Fig. 3-3 List menu

The settings for Mode, Reset List, Current Index etc are not relevant for the general description of the list editor. They are described in greater detail in chapter 4 in section "List Mode".

The Select List, Delete List and Edit List lines are always displayed. They are intended for the selection and deletion of lists and for the calling of editing functions.

Select List Opens a window in which a list out of 10 lists can be selected. In this line, the currently active list is displayed (see section "Select List").

Delete List Opens a window from which a list can be selected whose contents are to be deleted (see section "Delete List").

Edit List Selection of editing functions for list editing. When this item is selected, a pop-up menu with the following editing functions opens (see section "Edit List"):

- Insert** Insertion of elements into a list
- Fill** Filling of a list with elements
- Edit/View** Editing of individual elements of a list
- Delete** Deletion of elements of a list

Attenuator Mode	Auto	Normal setting. The mechanically switched attenuator switches in steps of 10 dB at fixed points. IEC/IEEE bus command : <code>OUTP:AMOD AUTO</code>
	Fixed	Level settings are made without switching the attenuator (see section "Non-Interrupting Level Setting"). IEC/IEEE bus command : <code>OUTP:AMOD FIX</code>
Atten Fixed Range		Indicates the level range of non-interrupting level setting in "Attenuator Mode Fixed".

Select List

- Mark the desired list using the rotary knob (see Fig. 3-4).
- Press the [SELECT] key or the rotary knob.

The selected list is included in the instrument setup. The selection window is closed. The selected list is displayed under Select List.

Selection: Select List

11.000 000 0000 GHz		-20.0 dBm	
List/Select List			
List0	0000	List1	0000
List4	0000	List5	0000
List8	0000	List9	0000

Fig. 3-4 Select List window

LIST0 The currently selected list, in this case List0, is marked in the selection window.

0100 The length of the list, in this case 100 elements, is indicated in the column right of the list designation.

Delete List

- Mark the desired list using the rotary knob (see Fig. 3-5).
- Press the [SELECT] key or the rotary knob.
The following query will appear:
"Are you sure? Press SELECT to confirm BACK to cancel".
- Press the [SELECT] key or the rotary knob.
The contents of the list will be deleted. If the query is answered by pressing the [BACK] key, the contents of the list will be retained. The selection window is automatically closed upon answering the query.

Selection: Delete List

11.000 000 0000 GHz		-20.0 dBm	
List/Delete List			
List0	0000	List1	0000
List4	0000	List5	0000
List8	0000	List9	0000
		Back	↵

Fig. 3-5 Delete List window

Edit List

When Edit List is selected, a pop-up menu with the editing functions opens.

Insert editing function (see Fig. 3-6)

The Insert function inserts a desired number of elements with constant or linearly increasing/decreasing values ahead of the element with the indicated start index. All elements already existing from the start index are shifted so that they come at the end of the range of elements to be inserted.

Elements are inserted in a list according to the following procedure:

When Insert has been selected, the menu cursor is on the Insert At menu item.

- Press the [SELECT] key or the rotary knob.
The menu cursor is on the value for At.
- Vary the index value by means of the rotary knob or enter an index value using the numerical keys and the [ENTER] key.
- Press the [SELECT] key or the rotary knob.
The menu cursor is on the value for Range.
- Vary the Range value by means of the rotary knob or enter a value using the numerical keys and the [ENTER] key.
- Press the [SELECT] key or the rotary knob.
The menu cursor is on the value for Start Frequency.
- Vary the start value for the frequency by means of the rotary knob or enter a value using the numerical keys and the [ENTER] key.
- Press the [SELECT] key or the rotary knob.
The menu cursor is on the value for Increment Frequency.
- Vary the value of the increment by means of the rotary knob or enter a value using the numerical keys and the [ENTER] key.
- Press the [SELECT] key or the rotary knob.
The menu cursor is on the value for Power.
- Vary the start value for the power by means of the rotary knob or enter a value using the numerical keys and the [ENTER] key.
- Press the [SELECT] key or the rotary knob.
The menu cursor is on the value for Increment Power.
- Vary the value of the increment by means of the rotary knob or enter a value using the numerical keys and the [ENTER] key.
- The cursor is on Execute. Press the [SELECT] key or the rotary knob to execute the insertion. The menu cursor goes back to Edit List.

Upon pressing the [BACK] key, the editing window is exited without any change being made. The menu cursor goes back to Edit List.

Selection: Insert

10.000 000 000 0 GHz		-20.0 dBm
List/Insert		
Insert At		0001
Range		0001
Start Frequency	10.000 000 000 0	GHz
Increment Frequency		0.0 Hz
Power		0.0 dBm
Increment Power		0.0 dB
Execute		
Back ↵		

Fig. 3-6 Edit function Insert

- Insert At** Input of start index.
- Range** Number of elements to be inserted.
- Start Frequency** Input of start value for the frequency.
- Increment Frequency** Input of increment between two successive frequency values. If 0 is entered as an increment, identical values will be inserted.
- Power** Input of start value for the power.
- Increment Power** Input of increment between two successive power values. If 0 is entered as an increment, identical values will be inserted.
- Execute** Starts the insertion. After the execution of the function, the menu cursor goes back to Edit List.

Fill editing function (see Fig. 3-7)

The Fill function overwrites a parameter with constant or linearly increasing/decreasing values within a defined range. If the [BACK] key is pressed, the editing window will be exited without any change being made.

If the fill range extends beyond the end of the list, the list is automatically extended.

Filling of a list is done in the same way as the insertion of elements in a list, see "Insert editing function".

Selection: Fill

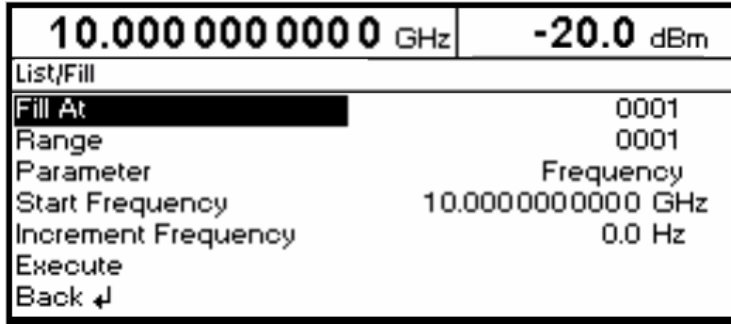

Fig. 3-7 Fill editing function

- Fill At** Input of start index.
- Range** Number of elements to be included.
- Parameter** Selection of parameters (frequency, power) to be filled. This menu option is not offered if a list contains only elements with one parameter.
- Start Frequency** Input of start value for the selected parameter. This option is offered only if Frequency is selected as a parameter.
- Increment Frequency** Input of increment between two successive values. If 0 is entered as an increment, the list will be filled with identical values. This option is offered only if Frequency is selected as a parameter.
- Power** Input of start value for the selected parameter. This option is offered only if Power is selected as a parameter.
- Increment Power** Input of increment between two successive values. If 0 is entered as an increment, the list will be filled with identical values. This option is offered only if Power is selected as a parameter.
- Execute** Starts the filling procedure. After the execution of the function, the menu cursor goes back to Edit List.

Edit/View editing function (see Fig. 3-8)

The Edit/View function allows viewing of a complete list or editing individual values of a list.

If the cursor is on a value in the left column of the list, the Edit/View mode can be exited by pressing the [BACK] key. The menu cursor goes back to Edit List.

There is no storage function for the list. This means that any modification of the list will be transferred to the internal data set and will be effective on exiting the Edit/View function.

Selection: Edit

11.000 000 000 0 GHz		-20.0 dBm	
List/Edit			
0001	10.000 000 000 0 GHz	0.0 dBm	List0
0002	10.100 000 000 0 GHz	0.1 dBm	Free 1900
0003	10.200 000 000 0 GHz	0.2 dBm	Len 0100

Fig. 3-8 Edit editing function

List Indication of list number

Free Available space. Free 1900, for example, means that there is free space for a total of 1900 pairs of values (elements) in the list memory.

Len Occupied space. Len 0100, for example, means that the current list occupies 100 elements in the list memory.

Selection of index ➤ Select an index by means of the rotary knob or enter an index value by means of the numerical keys.

Editing of parameters ➤ Select the parameter (frequency, power) to be edited by means of the [SELECT] key or the rotary knob.

➤ Vary the numerical value by means of the rotary knob or enter a numerical value using the numerical keys and the [ENTER] key.

➤ Upon pressing the [BACK] key, the menu cursor goes back to the column left of the current column or to the Edit List menu.

Delete editing function (see Fig. 3-9)

The Delete function deletes the elements of the indicated range. After a delete no gap is left in the list but the remaining elements move up. If the indicated range extends beyond the end of the list, the elements until the end of the list are deleted.

The inputs for deleting elements from a list are the same as for inserting elements into a list, see "Insert editing function".

Upon pressing the [BACK] key, the editing window will be exited without any change being made. The menu cursor goes back to Edit List.

Selection: Delete

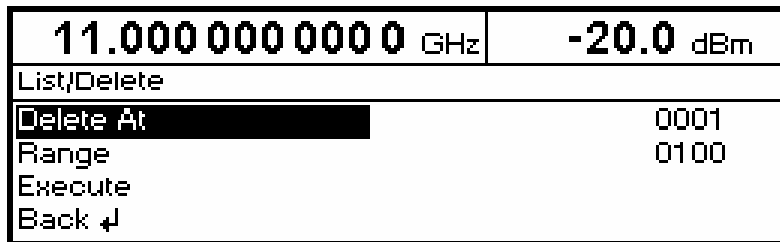

Fig. 3-9 Delete editing function

Delete At Input of first element to be deleted in a list

Range Number of elements to be deleted

Execute Starts the deletion. After the execution of the function, the menu cursor goes back to Edit List.

SAVE/RECALL – Storing/Calling of Instrument Settings

50 complete instrument settings can be stored in memory locations 1 to 50.

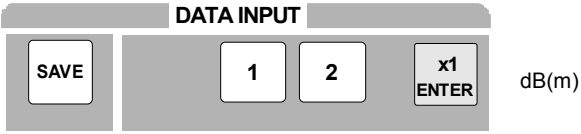
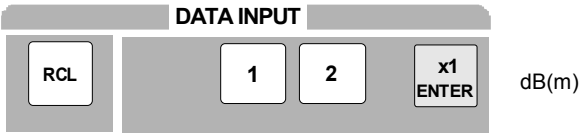
Operating Steps	Explanations
	<p>Store current instrument setting in memory location 12.</p>
	<p>Call instrument setting of memory location 12.</p>

The digital display during a save or recall entry is faded in a window.

If an instrument setting is stored in which a sweep was switched on, the sweep is started using the recall.

The parameter Exclude From Recall in the Frequency and Level-Level menus determines whether the saved RF frequency and RF level are loaded when an instrument setting is loaded, or whether the current settings are maintained.

Store IEC-bus command: "*SAV 12"

Call IEC-bus command: "*RCL 12"

Note: *The contents of lists, as they are used for the List mode or for user correction (Ucor), is not saved in the SAVE memory. It is stored under the respective list name and can be called. If instrument settings are called which go back to list data such as level setting using Ucor, the current list contents is used. If this has been altered, it is not identical to the list contents at the point of storing any more.*

Menu Summary

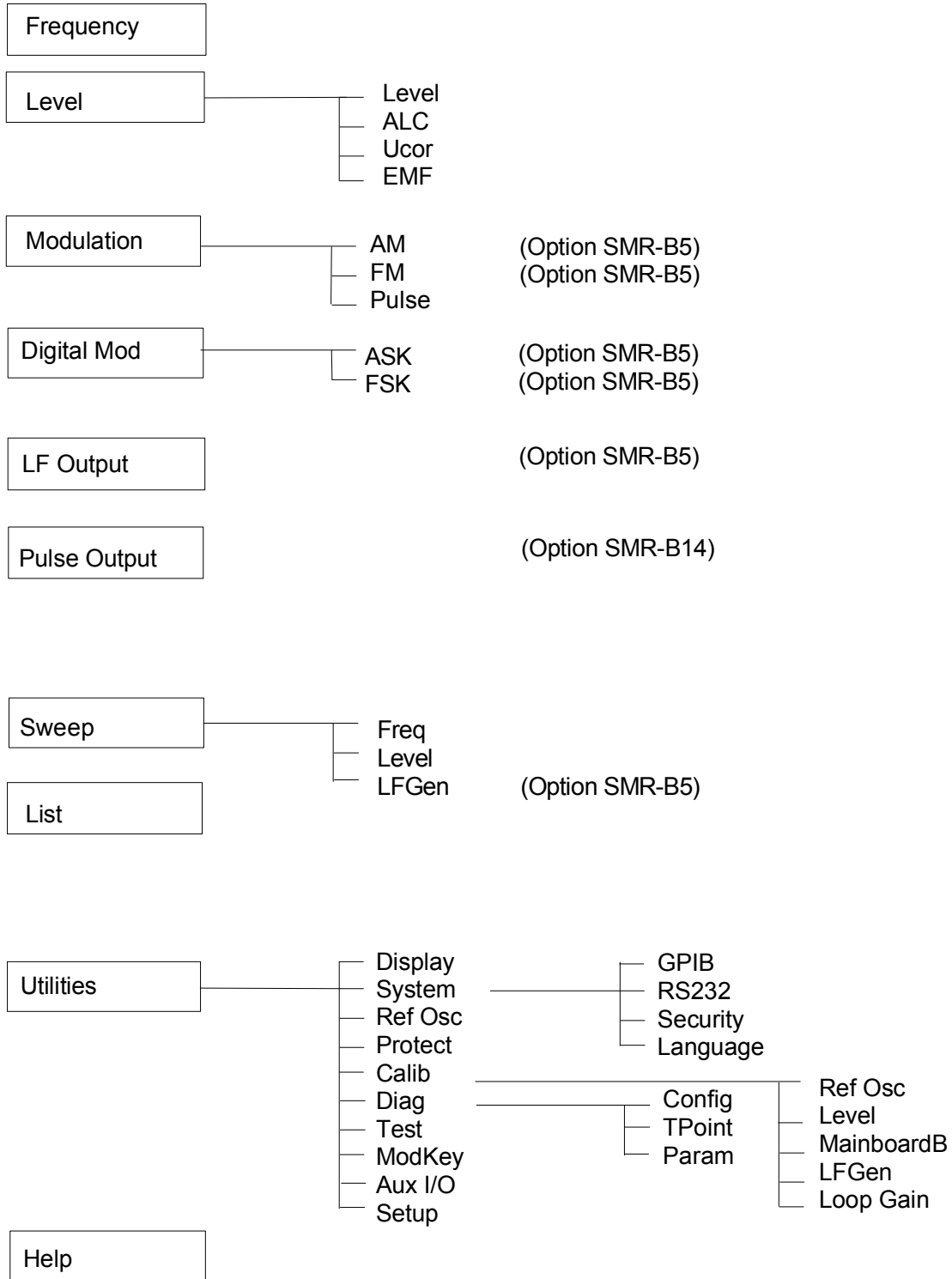

4 Index

This chapter contains the index for the present operating manual.

A

Attenuator	3.8
AUX interface	1.9

C

Call	
instrument settings	3.15
menu	3.4
Cursor	
digit cursor	3.1
menu cursor	3.1

D

Decimal point	1.5
Delete	
List	3.9
List entry	3.14
Digit cursor	3.1
Display	
design	3.1

E

Edit	
List	3.10
List entry	3.13
EMC	1.2
EXT ALC input	1.7

F

Fill	
List entry	3.12
Frequency	
accuracy	1.2
indication	3.1
Front panel	1.4
Fuse holder	1.9

H

Header field (display)	3.1
------------------------------	-----

I

IF input	1.11
Initial Status	1.2
Input	
correction	3.6
EXT ALC	1.7
EXT1/2	1.4
frequency	3.5
IF	1.11
level	3.5
PULSE	1.4

REF	1.9
RF	1.11
TRIG/STOP	1.11

Insert

List entry	3.10
Instrument settings	
call	3.15
store	3.15
Interface	
RS-232-C	1.10

K

Key

[←]	1.5, 3.6
[ASSIGN]	1.8, 3.4
[BACK]	3.2, 3.6
[BACK]	1.6
[FREQ]	1.4, 3.5, 3.6
[G/n]	1.5
[LEVEL]	1.4, 3.5, 3.6
[M/μ]	1.5
[MENU 1/2]	1.8, 3.4
[MOD ON/OFF]	1.7, 3.5
[PRESET]	1.3
[RCL]	1.4, 3.15
[RF ON/OFF]	1.7, 3.5
[SAVE]	1.4, 3.15
[SELECT]	3.2
[SELECT]	1.6
Backspace	3.6
ERROR	1.7
HELP	1.7
k/m	1.5
LOCAL	1.7
PRESET	1.7
STATUS	1.7
unit key	1.5
X1/Enter	1.5

L

Level

indication	3.1
setting (non-interrupting)	3.8
unit change	3.5
LF output	1.7, 1.9
List	
Delete	3.9
Edit	3.10
Select	3.9
List entry	
Delete	3.14
Edit	3.13
Fill	3.12
Insert	3.10

M

Memory	
locations	3.15
Memory CMOS-RAM	1.3
Menu	
access	3.2
call	3.4
fields	3.1
Modulation - AM	3.2
store	3.4
summary	3.16
Menu cursor	3.1
Message OVEN COLD	1.2

N

Non-interrupting level setting	3.8
Numeric input field	1.5
Numeric values	1.5

O

On/Off switch	1.8
Operation	
general instructions	1.1
putting into operation	1.1
Output	
LF	1.7, 1.9
PULSE/VIDEO	1.7, 1.11
REF	1.9
SYNC	1.11
V/GHz	1.11
X-AXIS	1.11

P

Parameter	
select	3.3
Power fuses	1.2
Power supply	1.2
Power supply connector	1.9
Presettings	1.3
PULSE input	1.7
PULSE/VIDEO output	1.11
Putting into Operation	
EMC	1.2
unpacking	1.1

Q

Quick selection	3.4
-----------------------	-----

R

Rear panel	1.9
Recall	
instrument settings	3.15
REF	
input/output	1.9
RF input	1.11
Rotary knob	1.6, 3.2, 3.3
RS-232-C interface	1.10

S

Sample setting	2.1
Save	
instrument settings	3.15
Scrollbar	3.2
Select	
List	3.9
Selection	
1-out-of-n	3.4
quick selection of menu	3.4
Status line (display)	3.1
Store	
instrument settings	3.15
menu	3.4
SYNC output	1.11

T

TRIG/STOP input	1.11
-----------------------	------

U

Unpacking	1.1
-----------------	-----

V

V/GHz output	1.11
Value	
change	3.3
inputs	3.3

X

X-AXIS output	1.11
---------------------	------



For your
User Documentation
CD-ROM